

JOHN FLUKE MFG. CO., INC.

P.O. Box 7428 Seattle, Washington 98133

MODEL 887A & 887AB

February 1, 1967

MODEL 887A & 887AB

**AC/DC DIFFERENTIAL
VOLTMETERS**

887A & 887AB serial no. 123 and above.

TABLE OF CONTENTS

SECTION	TITLE	PAGE
I	INTRODUCTION AND SPECIFICATIONS	1-1
	1-1. Introduction	1-1
	1-3. Input Power	1-1
	1-5. Receiving Inspection	1-1
	1-7. Specifications	1-2
II	OPERATING INSTRUCTIONS	2-1
	2-1. Location and Function of External Controls	2-1
	2-3. Input Power Connections	2-1
	2-5. Battery Charging	2-2
	2-7. Meter Zeroing	2-2
	2-9. Operation as a Conventional Voltmeter	2-2
	2-11. Operation as a DC Differential Voltmeter	2-2
	2-12. Operation as an AC Differential Voltmeter	2-3
	2-13. Recording Voltage Excursions about a Nominal Value	2-3
	2-16. Measuring High Resistances	2-3
	2-19. Additional Operating Techniques	2-4
	2-20. Ground Loops and Common Mode Voltages	2-4
	2-22. Errors Due to Waveform Distortion	2-4
	2-23. Effects of AC Components on DC Measurements	2-5
	2-24. AC Input Signal Instability	2-5
III	THEORY OF OPERATION	3-1
	3-1. Simplified Differential Voltmeter	3-1
	3-3. Circuit Functions	3-1
	3-6. Reference Power Supply	3-1
	3-8. Kelvin-Varley Divider	3-2
	3-12. Input Switching	3-2
	3-14. AC to DC Converter	3-3
	3-16. Null Detector	3-3
	3-21. Input-Power Switch Functions	3-3
IV	MAINTENANCE	4-1
	4-1. Periodic Maintenance	4-1
	4-4. Test Equipment Requirements	4-1
	4-6. The Calibration Cycle	4-1
	4-9. Performance Evaluation	4-2
	4-10. DC Checks	4-2
	4-13. AC Check	4-4
	4-15. Pre-Calibration Service and Adjustment	4-5
	4-17. Reference Supply Calibration	4-5
	4-18. Reference Supply Regulation	4-5

Continued page ii

Table of Contents Continued

SECTION	TITLE	PAGE
	4-19. Reference Supply Shift	4-5
	4-20. +18 Volt Supply Calibration	4-6
	4-21. +18 Volt Supply Output Ripple	4-6
	4-22. Chopper Drive Symmetry	4-6
	4-23. Chopper Drive Frequency	4-6
	4-24. Null Detector FET Voltage	4-6
	4-25. Null Detector Output Check	4-6
	4-26. Null Detector Zero Adjustment	4-6
	4-27. Null Detector Noise	4-6
	4-28. Null Detector Offset	4-6
	4-29. Negative Polarity Offset	4-6
	4-30. Null Detector Regulation	4-6
	4-31. 1 MV Gain Adjustment	4-8
	4-32. 100 UV Gain Adjustment	4-8
	4-33. 100 and 1000 Volt Null Sensitivity Check	4-8
	4-34. Recorder Output Check	4-8
	4-35. 100 and 1000 Volt Range Check	4-8
	4-36. Polarity Reversal Check	4-9
	4-37. Common Mode Check	4-9
	4-38. Converter FET Voltage	4-9
	4-39. Converter Output Voltage	4-9
	4-40. AC Sensitivity Check	4-9
4-41.	Calibration	4-9
	4-42. DC Calibration	4-9
	4-45. AC Calibration	4-9
	4-48. Kelvin-Varley Divider Evaluation	4-10
	4-50. Kelvin-Varley Divider Calibration	4-13
4-53.	Stability Evaluation	4-16
V	LIST OF REPLACEABLE PARTS	5-1
	5-1. Introduction	5-1
	5-3. Columnar Information	5-1
	5-4. How to Obtain Parts	5-1
	5-7. Abbreviations and Symbols	5-2
	5-8. Serial Number Effectivity	5-20
VI	ACCESSORIES	6-1
	6-1. Precision Voltage Dividers	6-1
	6-2. Isolation Amplifier	6-2
VII	APPENDIX A	
VIII	JOHN FLUKE MFG. CO. WARRANTY	
IX	SCHEMATIC DIAGRAM	

LIST OF ILLUSTRATIONS

FIGURE	TITLE	PAGE
Frontispiece	Model 887AB AC/DC Differential Voltmeter	iv
2-1.	Location and Function of Front-Panel Controls	2-1
2-2.	Location and Function of Rear-Panel Controls	2-2
2-3.	Measuring Resistance with the Model 887A	2-4
2-4.	Simplified Voltmeter Input Circuit	2-4
2-5.	Measurement Errors as a Function of Input-Signal Harmonic Distortion	2-4
3-1.	Simplified Differential Voltmeter	3-1
3-2.	Model 887A Functional Block Diagram	3-1
4-1.	Test Equipment Specifications	4-2
4-2.	Settings for Null Detector Check	4-3
4-3.	Equipment Connections for DC Calibration	4-4
4-4.	Reference Supply and External Kelvin-Varley Divider Check Setup	4-4
4-5.	Voltage Readout Dial Limits	4-5
4-6.	Equipment Connections for AC Calibration	4-5
4-7.	AC Checks	4-6
4-8.	Calibration and Maintenance Test Points	4-7
4-9.	Location of Internal Adjustments	4-8
4-10.	100 and 1000 Volt Null Sensitivity Check	4-9
4-11.	DC Calibration Adjustments and Tolerances	4-10
4-12.	AC Calibration Adjustments and Tolerances (sheet 1 of 2)	4-11
4-12.	AC Calibration Adjustments and Tolerances (sheet 2 of 2)	4-12
4-13.	Equipment Connections for Evaluating and Calibrating the Internal Kelvin-Varley Divider	4-13
4-14.	Kelvin-Varley Connections	4-14
4-15.	Kelvin-Varley Divider Error Limits	4-15
4-16.	Kelvin-Varley "A" Deck Adjustments	4-16
4-17.	Location of Transistor Terminals	4-17
4-18.	Performance Evaluation Record	4-18
5-1.	Final Assembly	5-3
5-2.	Chassis Assembly	5-5
5-3.	Front Panel Assembly	5-6
5-4.	Reference Supply Assembly	5-9
5-5.	Null Detector Assembly	5-12
5-6.	Kelvin-Varley Assembly	5-14
5-7.	Attenuator Assembly	5-15
5-8.	Converter Board Assembly	5-19



MODEL 887AB AC/DC DIFFERENTIAL VOLTMETER

SECTION I

INTRODUCTION AND SPECIFICATIONS

1-1. INTRODUCTION

1-2. The Model 887A Differential Voltmeter is line powered, and the Model 887AB Differential Voltmeter is either line or battery powered. Both instruments are half-rack width and are equipped with resilient feet and a fold-down bail for field or bench use. A single instrument may be mounted in a standard rack or two may be mounted side by side. The instrument is intended primarily as a differential voltmeter. It may also be used as a conventional transistorized voltmeter for rapid voltage measurement. When used as a dc differential voltmeter, the instrument draws essentially no current from the unknown-voltage source up to 11 volts. Above 11 volts the input resistance is 10 megohms. Common-mode voltage errors are virtually non-existent in the Models 887A and 887AB because of the high input-circuit leakage resistance---typically several hundred thousand megohms. In the Model 887AB, internal batteries permit

isolation from power-line grounds with attendant reduction of ground loop errors.

1-3. INPUT POWER

1-4. The Models 887A and 887AB are normally supplied with the power transformer connected for 115 volt operation. Instructions for connecting the transformer for 230 volt operation are printed on a decal fastened to the transformer.

1-5. RECEIVING INSPECTION

1-6. This instrument has been thoroughly tested and inspected before being shipped from the factory. Immediately after receiving the instrument, carefully inspect for damage which may have occurred in shipment. If any damage is noted, follow the instructions outlined in the warranty page at the back of this manual.

1-7. SPECIFICATIONS

AS A DIFFERENTIAL VOLTMETER

DC ACCURACY. $\pm(0.0025\%$ of input + 0.0001% of range + 5 uv) from 0 to ± 1100 vdc at 23° C. (nominal calibration temperature), less than 70% relative humidity. $\pm(0.005\%$ of input + 5 uv) from 0 to ± 1100 vdc within 16° C to 32° C (60° F to 90° F) temperature range, less than 70% relative humidity. Derate accuracy outside this temperature range at 0.00035%/C to extremes of 0° C and 50° C (32° F and 122° F).

NOTE. Thorough error analysis studies were made into total instrument stability taking into account the documented stabilities of individual components and utilizing probability and statistical methods. These studies indicate that typical instrument stability defined as a specification met by 80% to 90% of all instruments is 20 ppm (0.002%) peak-to-peak per year.

AC ACCURACY. At 23° C $\pm 1^\circ$ C (nominal calibration temperature) relative humidity less than 70%

INPUT VOLTAGE	FREQUENCY		
	30Hz to 5KHz	5KHz to 10KHz	10KHz to 20KHz
.001 to 500V	$\pm(0.05\%$ of input + 0.0025% range)	$\pm(0.07\%$ of input + 0.005% range)	$\pm(0.15\%$ of input + 0.01% range)
500V to 1100V	$\pm 0.1\%$ of input	$\pm 0.1\%$ of input	$\pm(0.15\%$ of input + 0.01% range)

Temperature range 13° C to 35° C (55° F to 95° F) relative humidity less than 70%

INPUT VOLTAGE	LOW FREQUENCY		BASIC FREQUENCY		HIGH FREQUENCY		
	5Hz - 10Hz	10Hz - 20Hz	20Hz - 5KHz	5KHz - 10KHz	10KHz - 20KHz	20KHz - 50KHz	50KHz - 100KHz
.001 - 1100V	$\pm(1\%$ of input + 25 uv)	$\pm(0.3\%$ of input + 25 uv)	$\pm(0.1\%$ of input + 25 uv)	$\pm(0.15\%$ of input + 25 uv)			
0.1 - 1100V					$\pm 0.3\%$ of input		
0.1 - 110V						$\pm 0.5\%$ of input	$\pm 1\%$ of input

Outside the 13° C to 35° C temperature range the above specifications may be derated at 0.003%/° C (below 5 KHz) or 0.005%/° C (above 5 KHz) to the extremes of 0° C to 50° C (32° F to 122° F)

AS A CONVENTIONAL VOLTMETER

AC ACCURACY. $\pm 3\%$ of range within frequency and voltage ranges listed under "ac accuracy as a differential voltmeter."

DC ACCURACY. $\pm 3\%$ of range.

RANGE

VOLTAGE RANGE	DC INPUT RESISTANCE	AC INPUT IMPEDANCE
1000-0-1000	10 MEG	1 MEG 40 Pf
100-0-100	10 MEG	1 MEG 40 Pf
10-0-10	10 MEG	1 MEG 40 Pf
1-0-1	10 MEG	1 MEG 40 Pf
*.1-0-.1	10 MEG	1 MEG 40 Pf
*.01-0-.01	10 MEG	1 MEG 40 Pf
*.001-0-.001	1 MEG	1 MEG 40 Pf
*.0001-0-.0001	1 MEG	1 MEG 40 Pf

NOTE. 10% overvoltage capability on each range.

* These ranges obtained by using null ranges with all voltage readout dials set to zero.

GENERAL

ELECTRICAL DESIGN. Completely solid-state.

INPUT RESISTANCE OF NULL DETECTOR. 10 megohms for two least sensitive null ranges, all input ranges; 1 megohm for two most sensitive null ranges, all input ranges.

REFERENCE ELEMENT. Temperature-compensated zener diode, temperature coefficient less than 1 ppm/°C over operating temperature range.

REGULATION OF REFERENCE SUPPLY. 0.0002% for 10% line voltage change.

STABILITY OF REFERENCE SUPPLY. 0.0005% peak-to-peak per hour. 0.0007% peak-to-peak per day. 0.0013% peak-to-peak per sixty days.

STABILITY OF INSTRUMENT. 0.00025% peak-to-peak per sixty days.

ACCURACY OF OFF-NULL DEFLECTION. ±5% of null range (±3% with voltage dials at zero).

KELVIN VARLEY DIVIDER ACCURACY. ±0.0012% of setting from 1/10 of full scale to full scale. ±0.0012% terminal linearity below 1/10 full scale.

RECORDER OUTPUT. Adjustable from 0 to ±20 mv minimum for full scale right and left deflection.

POLARITY. Front panel switch selects +DC, -DC and AC.

WARMUP TIME. dc 30 seconds; ac one minute.

COMMON MODE REJECTION. 130 db DC; 85 db at 60 Hz; 70 db at 400 Hz. Note: Battery operation of Model 887AB provides complete isolation from power system ground, for elimination of error due to ground loops.

OPERATING TEMPERATURE RANGE. 0°C to 50°C (see accuracy).

STORAGE TEMPERATURE RANGE.

Model 887A, -40°C to +70°C (-40°F to +158°F)

Model 887AB, -40°C to -60°C (-40°F to +140°F)

SHOCK. Meets requirements of MIL-T-945A and MIL-S-901B.

VIBRATION. Meets requirements of MIL-T-945A.

INPUT POWER. Model 887A 115/230 vac ±10%, 50 to 440 Hz; Model 887AB 115/230 vac ±10%, 50 to 440 Hz and rechargeable battery operation (minimum 30 hours operation on full charge).

WEIGHT.

Model 887A approximately 13 lbs.

Model 887AB approximately 14 lbs.

SIZE. 7" high, 8 1/2" wide, 14 3/4" deep.

SECTION II

OPERATING INSTRUCTIONS

2-1. LOCATION AND FUNCTION OF EXTERNAL CONTROLS

2-2. The functions of the front-and rear-panel controls are briefly described in Figures 2-1 and 2-2. Detailed operational procedures are explained in the paragraphs that follow.

2-3. INPUT POWER CONNECTIONS

2-4. The instrument is normally factory wired for 115 volt operation. 230 volt input power connections are described on a decal fastened to the power trans-

former. Input power connections are effected through a three-wire power cord. The third wire is a ground wire to connect the instrument chassis to the power system ground. When a two-to-three wire adapter is used, fasten the green wire to the power-system ground. The batteries in the Model 887AB can be checked by turning the POWER switch to BAT CHECK. If the batteries contain a satisfactory charge, the meter needle will come to rest in the BATTERY OK region and remain there for at least 10 seconds. If it does not, the batteries must be recharged according to the instructions of paragraph 2-5.

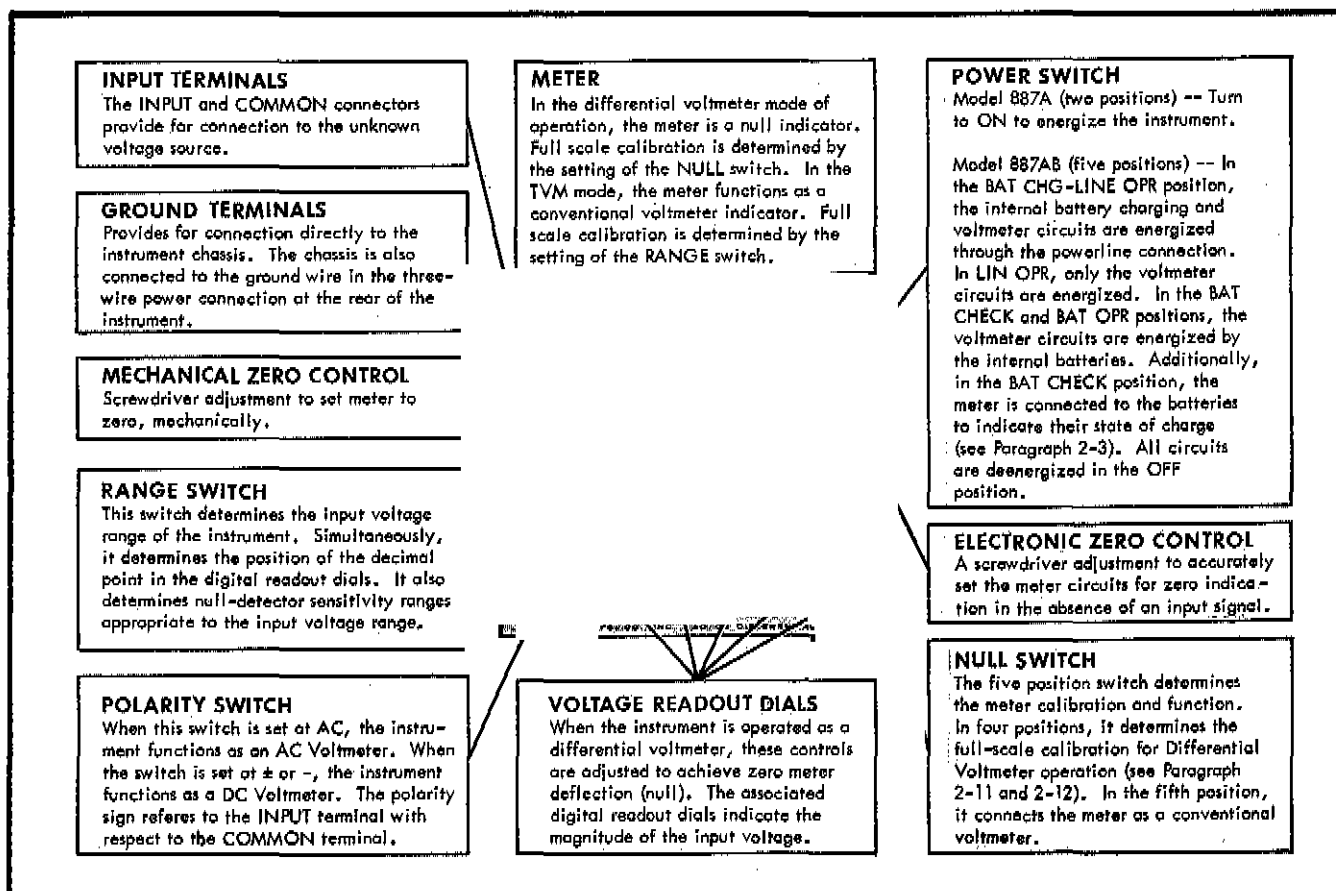

Figure 2-1. LOCATION AND FUNCTION OF FRONT PANEL CONTROLS

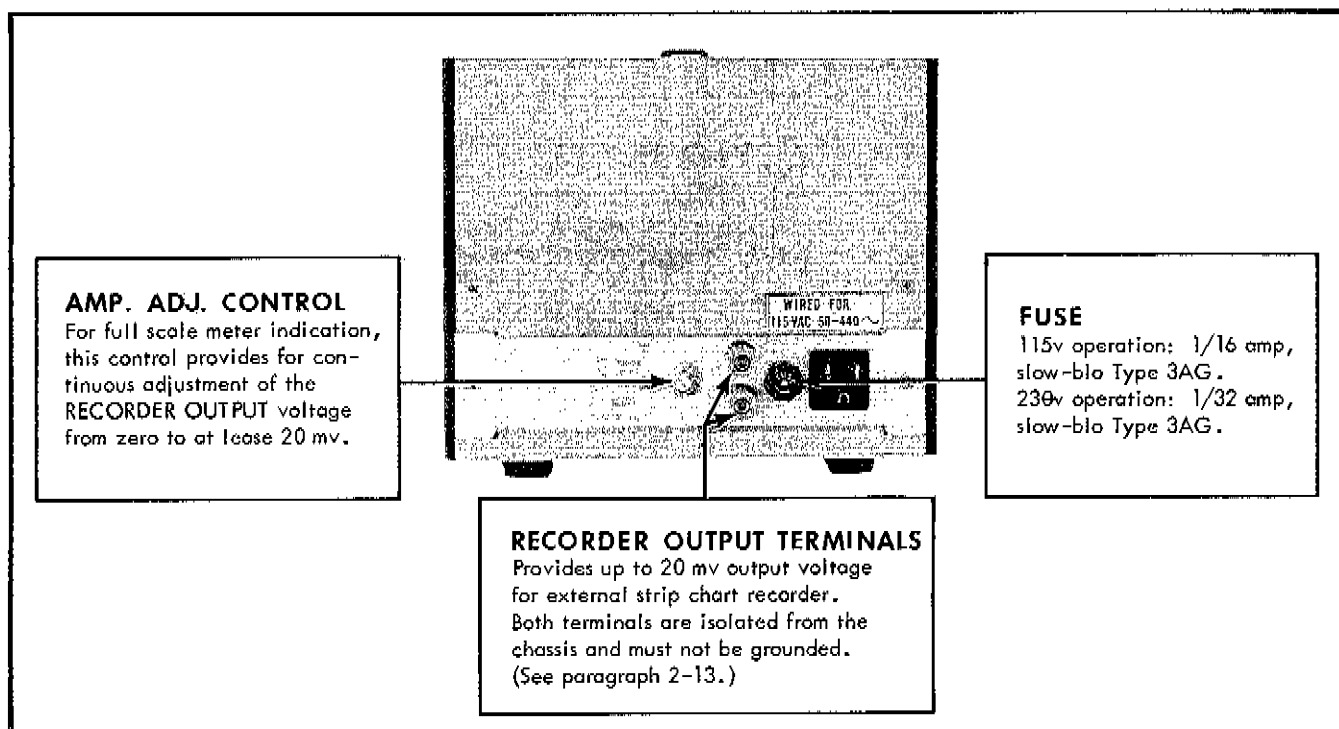

Figure 2-2. LOCATION AND FUNCTION OF REAR PANEL CONTROLS

2-5. BATTERY CHARGING

2-6. Should the BAT CHECK position of the power switch indicate low batteries use the following procedure:

- a. Connect power plug.
- b. Set POWER switch to BAT CHG-LINE OPR.

Batteries will be fully charged and capable of at least 30 hours of operation after 16 hours of charging. While the batteries are charging, the instrument may be used the same as for line operation.

CAUTION

Since overcharging decreases battery life, it is recommended that the batteries be charged for less than 48 hours and never more than one week. When used properly, the batteries will give more than 200 charge-discharge cycles of operation.

2-7. METER ZEROING

2-8. In the absence of an input signal, the meter should indicate zero. If it does not, adjust the meter circuits as follows:

- a. With the input power disconnected for at least three minutes, set the meter needle to zero with the mechanical zero control (see Figure 2-1).
- b. Turn the instrument on and allow it to warm up for 5 minutes.
- c. Set the RANGE switch to 1, the voltage readout dials to 0, and the NULL switch to 0.0001.

d. Short the INPUT post to the COMMON post and adjust the electronic ZERO control with a screwdriver for zero meter deflection.

e. Remove the short from the INPUT and COMMON posts.

2-9. OPERATION AS A CONVENTIONAL VOLTMETER

2-10. When operating the instrument as a conventional voltmeter (NULL switch at TVM) four input-voltage ranges are available. They are 1, 10, 100, and 1000 volts, and are selected by the RANGE switch. Additional lower-voltage ranges are available by operating the instrument as a differential voltmeter with the voltage readout dials set to 0. In this case, the NULL switch determines full-scale meter calibration.

- a. Select the desired full-scale deflection with the RANGE switch.
- b. Set the NULL switch to TVM.
- c. Set the polarity switch to + or AC as desired.
- d. Connect the unknown voltage to the INPUT and COMMON terminals. If one side is grounded, connect it to the COMMON terminal.
- e. Read the voltage magnitude on the meter scale. A positive voltage at the INPUT terminal will deflect the meter needle to the right.

2-11. OPERATION AS A DC DIFFERENTIAL VOLTMETER

A dc differential voltmeter measurement can be performed more quickly if the order of magnitude of the unknown voltage is known at the outset. If unknown, it can be quickly measured in the TVM mode as described

in paragraph 2-10. To measure the unknown voltage, proceed as follows:

- a. Verify correct meter zeroing as in paragraph 2-7.
- b. Set the RANGE switch to the lowest range setting that includes the unknown voltage magnitude.
- c. Set the NULL switch to the least sensitive range (i. e. fully counter clockwise).
- d. Set the voltage readout dials to the approximate magnitude of the unknown voltage.
- e. Connect the unknown voltage source to the INPUT and COMMON terminals. If one of the voltage-source terminals is grounded, connect it to the COMMON terminal. (See paragraph 2-19 for additional precautions.)
- f. Adjust the voltage readout dials for a zero indication on the meter, while turning the NULL switch to successively more sensitive positions.
- g. Read the magnitude of the unknown voltage from the readout dials.
- h. Fluctuations in the unknown voltage can be measured by observing the excursions of the meter needle. Full scale meter calibration is determined by the setting of the NULL switch.

2-12. OPERATION AS AN AC DIFFERENTIAL VOLTMETER

- a. If the approximate input voltage is not known, determine it by using the voltmeter in the AC TVM mode.
- b. Verify correct meter zeroing as in paragraph 2-7.
- c. Set the RANGE switch to the lowest range setting that includes the unknown voltage.
- d. Set the NULL switch to the least sensitive position (i. e. fully counter clockwise.)
- e. Set voltage readout dials to the approximate magnitude of the unknown voltage.
- f. Connect the unknown voltage to the INPUT and COMMON terminals.
- g. Adjust the voltage readout dials for a zero indication on the meter, while turning the NULL switch to successively more sensitive positions.
- h. Read the magnitude of the unknown voltage from the readout dials.
- j. Fluctuations in the unknown voltage can be measured by observing the excursions of the meter needle. Full scale meter calibration is determined by the setting of the NULL switch.

2-13. RECORDING VOLTAGE EXCURSIONS ABOUT A NOMINAL VALUE

- a. Verify correct meter zeroing as in paragraph 2-7.
- b. Set the ac-dc polarity switch to the desired position.
- c. Connect the input voltage between the INPUT and COMMON terminals. If one side is grounded, connect it to the COMMON post. Deflection of the meter needle to the left indicates a negative voltage at the INPUT terminal. Turn the polarity switch to negative.
- d. Set the RANGE switch to the lowest range giving an on-scale deflection.
- e. Set the digital readout dials to the value determined in step d.

f. Turn the NULL switch to the lowest position that still allows excursions to stay on scale.

g. Observe the voltage excursions on the meter. Deflections to the right indicate an increase in amplitude; to the left, a decrease in amplitude.

2-14. When recording voltage excursions it must be remembered that the leakage resistance, recorder to ground, must be at least 10,000 megohms. Less resistance will impair the accuracy of the voltmeter. If the recording instrument has less than 10,000 megohms input resistance, an isolation amplifier must be used. The FLUKE Model A88 is recommended for this application as it permits the use of any recorder without regard to input isolation characteristics.

2-15. To use the Model 887A with an isolation amplifier and recorder:

- a. Short the INPUT terminal to the COMMON terminal and set the voltmeter switches to:

RANGE	10
NULL	1
readout dials	1.0000

The meter will indicate full scale deflection (-1.0). This feeds up to a maximum of 20 mv to the RECORDER output terminals, depending on the adjustment of the AMP ADJ control.

b. Energize the recorder and amplifier. Connect the isolation amplifier to the RECORDER OUTPUT terminals.

c. Adjust the AMP ADJ control for the desired maximum deflection of the recorder.

d. Remove the short from the INPUT and COMMON terminals.

e. Check for excessive current leakage as follows: Connect a voltage to the input of the Model 887A and measure its magnitude in the most sensitive null range. Alternately connect and disconnect the recorder leads to the voltmeter. A meter deflection of more than one major scale division (10% of the null range) indicates excessive leakage.

2-16. MEASURING HIGH RESISTANCES

2-17. For the quick determination of resistance values in the range from 10 to 11,000 megohms proceed as follows:

- a. Verify correct meter zeroing as in paragraph 2-7.
- b. Set the NULL switch to 1 and the RANGE switch to 10.
- c. Connect unknown resistance to the INPUT and COMMON terminals. Use short isolated leads to minimize errors due to lead leakage resistance.
- d. Adjust the readout dials for full-scale meter deflection (-1.0). If full-scale deflection cannot be obtained with the NULL switch at 1, change it to 0.1 or 0.001.
- e. Determine the value of the unknown resistance from the table of Figure 2-3.

2-18. With the RANGE switch set at 10, the following formula may be used to determine unknown resistance values.

$$R_x = R_i \left(\frac{E}{E_m} - 1 \right) \text{ megohms}$$

Where:

R_x is the unknown resistance in megohms.

E is the voltage indicated on the readout dials.

E_m is the voltage indicated on the meter.

R_i is the input resistance of the TVM circuit in megohms. It is 10 for the 1 and 0.1 positions of the NULL switch and 1 for the 0.01 and 0.001 positions when the RANGE switch is set at 10.

RANGE OF UNKNOWN	NULL SW. POSITION	WHEN METER INDICATES FULL SCALE:
10M Ω to 100M Ω	1	MULTIPLY READOUT BY 10 and SUBTRACT 10
90M Ω to 1090M Ω	0.1	MULTIPLY READOUT BY 100 AND SUBTRACT 10
1,000M Ω to 11,000M Ω	0.001	MULTIPLY READOUT BY 1000.

Figure 2-3. MEASURING RESISTANCE WITH THE MODEL 887A

2-19. ADDITIONAL OPERATING TECHNIQUES

2-20. GROUND LOOPS AND COMMON MODE VOLTAGES

Ground loops may result when the Model 887A, in which the chassis and case are grounded, is connected to an instrument or signal-source ground at a different potential. Current may flow in this completed circuit causing erroneous meter readings. To avoid this condition the Model 887A should be connected to the power source through a 3-pin to 2-pin isolation plug. This disconnects the instrument from the external ground and effectively breaks the ground loop circuit.

2-21. Common mode voltages may result when the circuit element to which the instrument is connected is grounded through a second element. The situation is illustrated in the simplified diagram of Figure 2-4. In this example, if the COMMON and GROUND terminals are connected to an ac source, R_2 is shunted increasing the current through R_1 and causing an erroneous measurement. During dc measurements, error is determined by the leakage resistance from the COMMON terminal to ground. The dc common-mode rejection ratio while measuring voltages up to 1000V at a relative humidity of 70% or less, is 5,000,000 to one or 0.2 uv/volt. A 0.1 uf capacitor (C_1) is connected from the COMMON terminal to the GROUND terminal. When making common-mode measurements, this capacitor may become charged. This could lead to errors in suc-

2-4

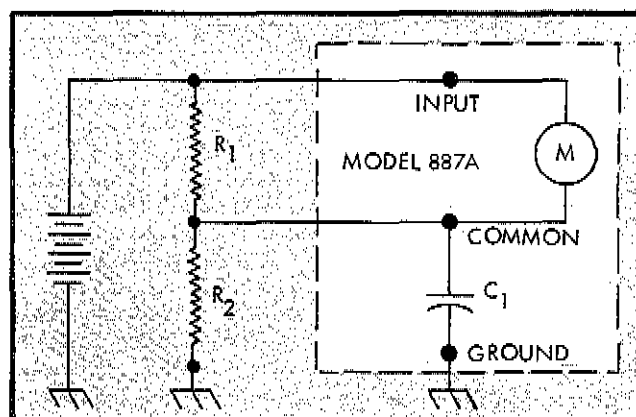

Figure 2-4. SIMPLIFIED VOLTMETER INPUT CIRCUIT

ceeding low voltage measurements (under 5 volts). Connect the shorting link from the COMMON terminal to the GROUND terminal for a few seconds to discharge C_1 . When measuring ac common-mode voltages, a 3-prong to 2-prong line-cord isolation plug must be used. An ac load might otherwise be placed on the voltage source by capacitor C_1 .

2-22. ERRORS DUE TO WAVEFORM DISTORTION

The AC to DC Converter output voltage is 1.11 times the average value of the ac input signal. Therefore, if the input is not a true sinusoid the output will probably be in error. The magnitude of the error will be in proportion to the magnitude of the distortion and its phase and harmonic relation to the fundamental. Figure 2-5 indicates error magnitude as a function of harmonic distortion.

ORDER OF HARMONIC	% DISTORTION	% ERROR FROM TRUE RMS	
		MAX. POSITIVE	MAX. NEGATIVE
ANY EVEN HARMONIC	0.1	0.000	0.000
	0.5	0.000	0.0001
	1.0	0.000	0.005
	2.0	0.000	0.020
THIRD HARMONIC	0.1	0.033	0.033
	0.5	0.167	0.168
	1.0	0.328	0.338
	2.0	0.667	0.687
FIFTH HARMONIC	0.1	0.020	0.020
	0.5	0.099	0.101
	1.0	0.195	0.205
	2.0	0.380	0.420

Errors depend upon phase relationship between fund. and harmonic. Error may be any value between max. positive and max. negative.

Figure 2-5. MEASUREMENT ERRORS AS A FUNCTION OF INPUT-SIGNAL HARMONIC DISTORTION

2-23. EFFECTS OF AC COMPONENTS ON DC MEASUREMENTS

The triple-section low-pass filter at the input to the Null Detector attenuates ac signal components. At frequencies below 100 Kz the filter becomes less effective. When the frequency is close to a multiple or submultiple of the 83 Hz chopper frequency, the meter needle will oscillate at the difference frequency. If error causing ac components are encountered, additional filtering will be required. For single frequency signals, a twin-T filter is effective and has the advantage of low total series resistance. For variable frequency signals, an

ordinary low pass filter may be used.

2-24. AC INPUT SIGNAL INSTABILITY

Most ac sources are not stable enough to be measured in the most sensitive null range. For example, if 1.0 volt is measured with the RANGE switch set at 1 and the NULL switch set to 0.0001, the null detector sensitivity is 100 uv full scale. Since 100 uv is 0.01% of 1 volt, an ac source with a stability less than $\pm 0.01\%$ will cause meter fluctuations. In addition when using the most sensitive null range, converter noise may cause meter deflection if the input signal is below 1 mv.

SECTION III

THEORY OF OPERATION

3-1. SIMPLIFIED DIFFERENTIAL VOLTMETER

3-2. The basic operating principle of a differential voltmeter is the comparison of an unknown voltage to a calibrated reference voltage. The principle is illustrated in Figure 3-1. Here, the reference voltage is represented as a battery. A calibrated voltage divider, R₁, provides an adjustable output. The unknown input voltage is connected to input terminals A and B. When the voltage divider is adjusted so that the two voltages are equal, there will be no current flow in the meter. This condition is termed a null. The magnitude of the unknown voltage is equal to the product of the reference voltage and voltage-divider ratio. In a practical differential voltmeter, the voltage divider controls are calibrated in terms of the input voltage. Typical accuracies of this type of dc voltage measurement are of the order of 0.005%.

3-3. CIRCUIT FUNCTIONS

3-4. The principle elements of the Model 887A Voltmeter are depicted in the Functional Block Diagram of Figure 3-2. In this diagram, the Reference Supply battery of Figure 3-1 has been replaced by the Reference Power Supply; the voltage divider has been replaced by the Kelvin-Varley Divider; and the Meter has been replaced by the Null Detector. Additionally, the input circuit has been modified to include an AC to DC Converter and a DC Attenuator.

3-5. The Model 887A has three basic operating modes: dc, ac, and TVM. In the dc mode, the input voltage is connected through the DC Attenuator to the NULL Detector and Kelvin-Varley Divider. The DC Attenuator attenuates input voltages above 11 volts to values within the 0-to-11 volt operating range of the Kelvin-Varley Divider. The Kelvin-Varley Divider is adjusted to make the output voltage equal to the unknown input voltage. When they are equal, the NULL Detector will indicate zero on the meter. The magnitude of the unknown voltage can then be read from the front-panel dials which are mechanically linked to the Kelvin-Varley Divider. In the ac mode, the input signal is connected to the AC to DC Converter where the ac voltage is converted to a dc voltage proportional to the average value. This dc

voltage is then compared to the reference voltage as in the dc mode. In the TVM mode, the Kelvin-Varley Divider and Reference Power Supply are disconnected and the input signal is connected directly to the Null Detector. In this case the Null Detector functions as a conventional voltmeter.

3-6. REFERENCE POWER SUPPLY

3-7. The Reference Power Supply is part of the -18 volt Power Supply. Both of these supplies are energized through diode CR102 and filter network R106, C102 from the power transformer terminals 10 and 11. In the Model 887AB, unregulated dc is also supplied by a pair of 9.6 volt batteries designated BT3 on the functional schematic diagram. Voltage in either case is supplied to series-pass transistor Q101 which accomplishes voltage regulation in the following manner. A voltage proportional to the output voltage is developed at the base of differential amplifier Q103A by voltage divider R109, R110, and R111. At the other input, Q103B, zener diodes CR103 and CR104 establish a reference voltage. Output voltage variations with respect to the reference voltage are amplified and appear as an error signal at the collectors of Q103A and Q103B. The error signal is amplified additionally by the differential amplifier Q104 - Q105. Output from Q104 is fed to the base of Q101. Voltage drop across Q101 is therefore controlled

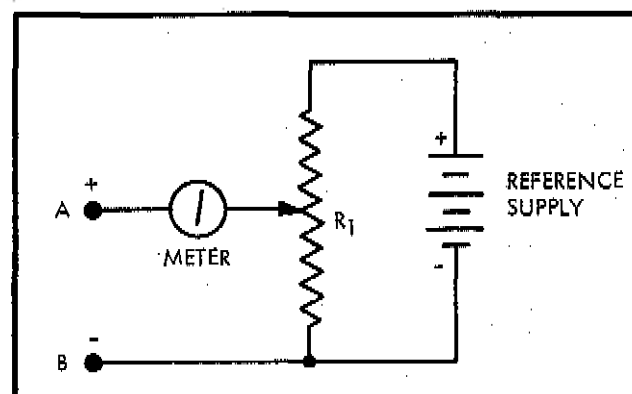

Figure 3-1. SIMPLIFIED DIFFERENTIAL VOLTMETER

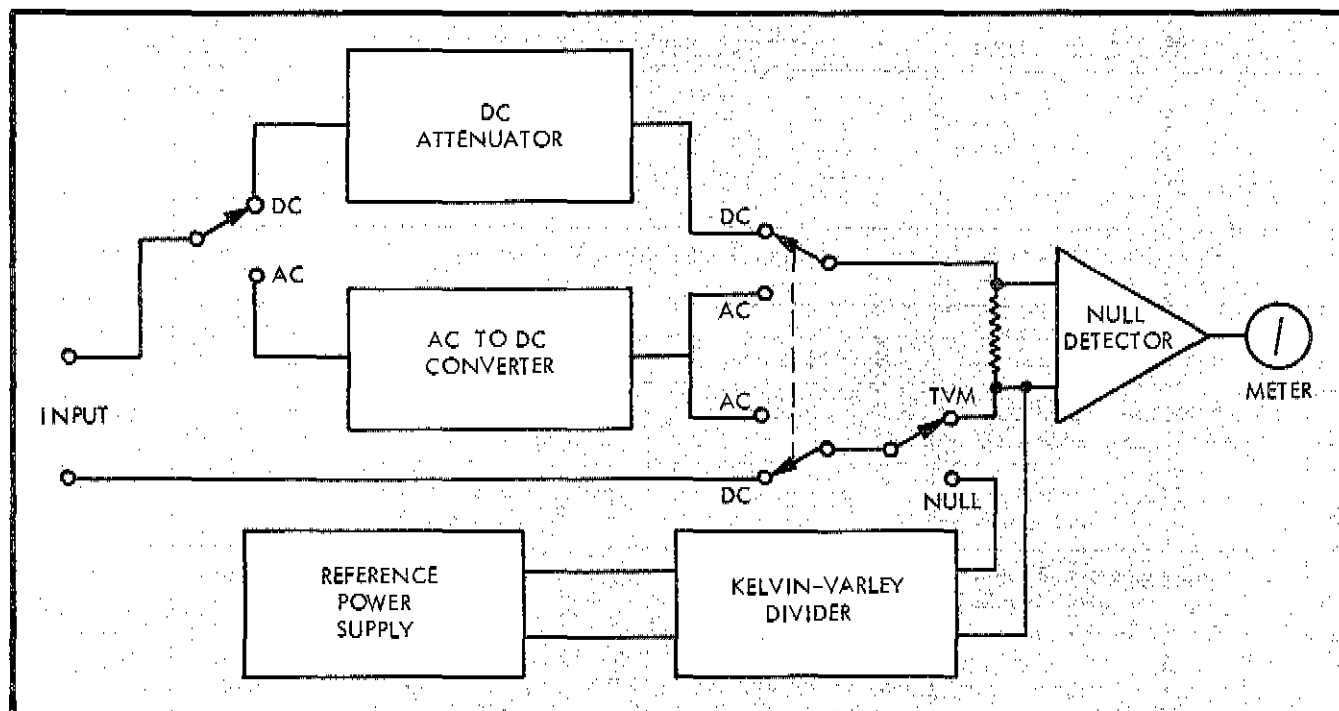

Figure 3-2. MODEL 887A FUNCTIONAL BLOCK DIAGRAM

by the differential amplifier to maintain a constant -18 volts output. Q102 is in the circuit to insure that Q101 will conduct at all times. (Under certain conditions of low battery voltage Q101 may not operate by itself). The constant -18 volts is connected to one end of resistor R117. The other end of this resistor is connected to the constant voltage developed across Zener diodes CR103 and CR104. Because the resistor is connected between two constant voltage points, the current through the resistor is constant. The value of R117 is selected for optimum current through the Zener diodes. The voltage developed across Zener diodes CR103 and CR104, although extremely stable, can be of a magnitude from 11.4 to 13 volts. Resistors R119 and R120 function as an adjustable voltage divider to set the output voltage at exactly 11 volts. Additionally, resistors R121, R122, and R123 function as a voltage divider in the 1-volt range to reduce the reference voltage to 1.1 volt. It is important to note that the output voltage at this point is dependent upon constant current in the load.

3-8. KELVIN-VARLEY DIVIDER

3-9. To insure constant current loading on the Reference Power Supply, the Kelvin-Varley Divider must present a constant input resistance as the division ratio is changed. The first order of division occurs in the resistive divider associated with dial A (R301 through R326). The resistors of this divider are arranged in twelve equal parts of 5000 ohms each. The two contacts of switch S5 connect the second order resistive divider (R327 through R337) in parallel with any two adjacent parts of the first divider. The total resistance of the second-order divider is 10,000 ohms. Connecting it in parallel with two first-order divider parts, results in a total resistance of 5000 ohms. This resistance in

series with the remaining ten 5000 ohm parts, provides eleven equal voltage steps in association with dial A. Since the Reference Power Supply output is 11 volts, Dial A is calibrated in one-volt increments from zero to 11 volts.

3-10. Second-, third- and fourth-order divisions occur in association with dials B, C, and D. As with switch S5, switches S6, S7, and S8 connect the total resistance of a divider in parallel with two adjacent parts of an eleven equal part divider. And, like dial A, the remaining dials are calibrated in zero-to-ten increments. Dial B in 100 mv steps, dial C in 10 mv steps and dial D in 1 mv steps. Dial E, is a variable resistor rather than a switch but the same principle applies.

3-11. The resistors of the Kelvin-Varley Divider are especially selected for tolerance and temperature coefficient. In the first-order divider, resistance values are trimmed to six-place accuracy with 2 ohm variable resistors. In short, a great deal of control is exercised in manufacturing the Kelvin-Varley Divider, and barring catastrophic failure, resistance values should remain well within tolerance limits for several years of normal usage.

3-12. INPUT SWITCHING

3-13. The ac-dc polarity switch, S4, selects the operating mode of the instrument. In the dc mode (either + or -), the unknown voltage is connected to the RANGE switch S2. In the 1 v and 10 v positions, S2 connects the input voltage directly to the NULL switch S3. With the RANGE switch in the 100 v and 1000 v positions, resistors R100, R101, R102, and R103 divide the voltage by 100. The 10 K variable resistor R103 is used

to calibrate the division ratio. Operation in the ac mode connects the input voltage to the AC or DC Converter.

3-14. AC TO DC CONVERTER

3-15. The comparison section of the Model 887A can utilize only dc voltage. As a result, ac input voltages must be converted to dc voltages. This function is achieved in the AC to DC Converter. The attenuator has four sections, one for each position of the RANGE switch. In the 1 volt position, the input is connected through the ac-dc polarity switch, S4, directly to the input of the amplifier. In other switch positions, attenuators reduce the input voltage by factors of 1000, 100, and 10. The first stage of the amplifier is an n-channel field-effect transistor. The field-effect transistor provides high input impedance as well as low input noise characteristics. The next four stages are two transistor doubletons Q502 Q503, and Q504 Q506. Q505 acts as a dynamic load, increasing the output impedance of the amplifier. The amplifier has a midband loop gain of approximately 70 db with a virtually flat frequency response from 20 hz to 20 KHz. The output of the amplifier is fed to the rectifier/filter which uses a pair of diodes CR503 and CR504 to convert the ac to pulsating dc. At this point negative feedback is returned to the gate of the field effect transistor. The negative feedback makes the amplifier practically noise free and relatively insensitive to gain changes in individual stages.

3-16. NULL DETECTOR

3-17. The Null Detector is a chopper-modulated current-feedback amplifier. An important characteristic of this type of amplifier is the switching reed in the input circuit. This switching reed or chopper, as it is often called alternately switches the input of the high-gain amplifier between the input signal and a reference voltage. As a result the ac-coupled amplifier amplifies the difference between these two signals; effectively eliminating long-term dc shifts in the amplifier.

3-18. The switching reed is actuated by a chopper drive coil, which in turn is driven by a chopper-driver multivibrator. The multivibrator switching elements are transistors Q106 through Q109. The frequency of the multivibrator is 83 Hz. When the multivibrator switches in a direction to connect the switching reed to the input signal, transistor Q206 is cut off. Conversely, when the multivibrator switches the reed to the reference voltage, transistor Q206 is turned on, clamping the junction of C217 and R225 to the Null Detector circuit common. When the switching reed is actuated to the input signal connection, the amplifier amplifies the

difference signal, charging capacitor C219 and causing current to flow in the meter circuit. Simultaneously, a voltage is developed at the junction of R229 and the meter which is proportional to the meter current. This voltage is fed back to the voltage reference circuit and establishes a new voltage reference. Then, when the switching reed is switched back to the voltage reference, the output of the amplifier is clamped by Q206. The current feedback voltage and the meter indication is maintained by the discharge of C219 through the meter circuit. The net result is the charge or discharge of C219 in discrete steps by the amplified voltage difference between the input signal and the fed back reference voltage.

3-19. The high-gain ac amplifier utilizes a FET in the input circuit for high input impedance and low noise. The remaining two stages are transistor doubletons, each having dc-coupled negative feedback for stability (through R216 and R222). The input circuit includes a low-pass filter (R201, C201, R202, C202, R203, and C203) for the suppression of noise and ac signals, and a neon glow lamp (DS201) to protect the FET from damaging transients or overload voltages.

3-20. The input switching circuits for the Null Detector determine the operating mode for the instrument. When the NULL switch is placed in the TVM position, Section S3C connects the front-panel COMMON connector to the Null Detector common. Simultaneously, Sections S3G, S3H, and S3E connect the INPUT connector to the Null Detector input through a fixed voltage divider. When the NULL switch is placed in any of the other four positions, section S3C connects the front-panel COMMON connector to the Kelvin-Varley Divider for differential voltage measurements.

3-21. INPUT-POWER SWITCH FUNCTIONS

3-22. The Model 887A has only one Power Switch function. Switch S1 connects the ac input power to the transformer. The Model 887AB has three Power Switch functions. S1A and S1B connect the ac to the transformer in the LINE OPR and BAT CHG positions. AC is disconnected in the OFF, BAT CHK, and BAT OPR positions. S1C, S1D, and S1E, connect the transformer to power supply inputs. In addition BT1, BT2, and BT3 are connected to the power supply inputs in the BAT CHK and BAT OPR positions. BAT CHG position connects an additional diode and resistor to each of the batteries to provide battery charging during line operation. S1G and S1H connect the meter across the output of the Null Detector in all positions but BAT CHK. In the BAT CHK position the meter is connected from the -18 volts to common.

SECTION IV

MAINTENANCE

4-1. PERIODIC MAINTENANCE

4-2. Since the Model 887A and the Model 887AB are completely enclosed units, the need for cleaning is greatly reduced. If the instrument is used in a clean, comparatively dust-free area, routine cleaning will probably not be necessary. If it is necessary to remove the covers, exercise extreme care to avoid introducing dirt or grease from the hands or test instruments. Special care has been taken to prevent leakage across critical switch wafers, areas of some printed circuit boards, and from the printed circuit boards to chassis ground. The POWER, RANGE, NULL, polarity, and all voltage readout switches are vacuum impregnated with Dow Corning silicone oil. These switches are also isolated from the front panel with Lexan spacers. The printed circuit boards are coated with Epocast 8267. Also, the printed circuit boards are isolated from chassis ground by polyethelene grommets.

4-3. Use the following procedures to clean the instrument.

CAUTION!

Avoid touching polyethelene grommets. The normal accumulation of oil on the hands may be enough to cause excessive leakage.

a. With low-pressure, clean, dry air, remove accumulations of dust and foreign material. Pay particular attention to the input binding posts, binding post wiring, switches, and polyethelene grommets which insulate printed circuit boards from the chassis.

b. Clean the polyethelene grommets, binding posts, and front panel with anhydrous denatured ethyl alcohol or a pressure can of Freon TF Degreaser (Miller-Stephenson Chemical Co., Inc.) and, as necessary, a clean cloth or a cotton swab.

CAUTION!

Do not use Metriclene, acetone, laquer thinner, or any other methyl ethyl ketones. They will react with the Lexan rotors on the switches. Also, be careful not to saturate the switch contacts as they have been lubricated for the life of the switch.

c. As necessary, clean all exposed insulating switch surfaces with denatured alcohol using a small, stiff-bristled brush, wrapped in a clean cloth.

d. After cleaning and waiting until the alcohol has completely dried, recoat the exposed insulating material with a solution of Dow Corning 200 having a viscosity between 5 and 20 centistokes.

4-4. TEST EQUIPMENT REQUIREMENTS

4-5. Test equipment for Calibration is listed in Figure 4-1. In each case this is the recommended equipment and if it is not available comparable equipment may be used.

4-6. THE CALIBRATION CYCLE

4-7. The accuracy of a precision voltmeter such as the Model 887A is dependent upon its ability to stay within acceptable tolerance limits. This ability, or instrument stability, depends on the change in value of the components in the instrument with time. Each instrument will thus have a stability that varies from the average stability of a group of instruments. Measurements of instrument stability indicate that the initial calibration interval should be six months. After the first few calibration intervals, past performance will allow the interval to be adjusted to fit the instrument stability and the degree of usage.

4-8. A Performance Evaluation has been included as the first part of a four part calibration procedure in order to measure instrument stability. This procedure includes a Performance Evaluation Record (Figure 4-18) for recording observations. Pre-Calibration Service and Adjustment is the second part. This part consists of a series of performance checks and calibration adjustments to prepare the instrument for final calibration. The third part, Calibration, consists of a complete ac and dc calibration procedures as well as Kelvin-Varley evaluation and calibration procedure. The final step is the Stability Evaluation which measures the instruments performance with respect to short periods of time.

NOMENCLATURE	SPECIFICATIONS REQUIRED	RECOMMENDED INSTRUMENT
VTVM	Range: 0-40 vac, 0-300 vac Accuracy: $\pm 5\%$ DC Input Characteristics: 10 meg/5 pf AC Input Characteristics: 1 meg/100 pf	RCA Voltohmyst
RMS Voltmeter	Range adequate to measure 200 uv, $\pm 5\%$, at 120 Hz.	John Fluke Mfg. Co. Model 910A
Autotransformer	103 - 127 v, 1 amp. 207 - 253 v, 1/2 amp.	General Radio Corp. Model W5MT3 Variac
DC Differential Voltmeter	Range: 10 - 20 vdc, $\pm 0.05\%$ Null Range: at least 10 mv.	Almost any John Fluke Mfg. Co. Differential Voltmeter
Standard Cell	Accuracy: $\pm 0.0005\%$	Guildline Mfg. Co. Model 9152/P4
Reference Voltage Divider	Input voltage: 10-100-1000 vdc Output Voltage: 1-10-100-1000 vdc Accuracy: $\pm (0.001\% + 2 \text{ uv})$ Divider Current Adjustment Range: to a minimum of 1 ppm and a maximum of 5 ppm on all ranges.	John Fluke Mfg. Co. Model 750A
Null Detector	Range: 1 uv to 1 mv, end scale	John Fluke Mfg. Co. Model 845A
AC Source	Voltage output: 1 - 1000 volts Frequency range: 35 Hz to 100 kHz Stability: 0.01%/hr. Distortion: 0.05% or less Resolution: 0.0005% or better.	Optimization Inc. Model AC 104
Counter	Adequate to measure 84 Hz ± 2 Hz.	CMC Model 201C
Transfer Standard	Voltage Range: 1 - 1000 volts Frequency response: 400 Hz to 100 kHz Accuracy: 0.01%	John Fluke Mfg. Co. Model 540B
Lead Compensator	Resolution: 0.1 milliohm Divider resistance ratio from 1:1 to 10:1	John Fluke Mfg. Co. Model 721A
Kelvin-Varley Voltage Divider	Input Resistance: 100k Ratio accuracy: 1 ppm Seven decades	John Fluke Mfg. Co. Model 720A
Voltage Standard	Output voltage: 1 - 1000 vdc Output Current: 0-6 ma Stability: $\pm 0.0005\%$ /hr. Resolution: $\pm 0.0005\%$ Accuracy: $\pm 0.004\%$	John Fluke Mfg. Co. Model 332A

Figure 4-1. TEST EQUIPMENT SPECIFICATIONS

4-9. PERFORMANCE EVALUATION

4-10. DC CHECKS

4-11. NULL DETECTOR CHECK. The null detector is checked in this procedure by using the instruments internal reference supply and Kelvin-Varley divider. This is possible because the reference supply and Kelvin-Varley divider are a few hundred times more accurate

than the null detector. If the instrument fails to pass this check, there is a remote chance that the cause is due to a faulty reference supply or Kelvin-Varley divider. In this case, the measurement of an appropriate voltage in the TVM mode will indicate if the null detector is operating properly. Proceed as follows:

a. Set 887A meter to zero with mechanical zero control.

- b. Set POWER switch to LINE OPR with 887AB or to ON with 887A and allow a warmup period of 5 minutes.
- c. Short INPUT post to COMMON post.
- d. Set ac-dc switch to + (positive).
- e. Set switches on voltmeter as shown in Figure 4-2. Meter should indicate within 1-1/2 small scale divisions ($\pm 3\%$ of null range) of value shown in Figure 4-2.
- f. Record meter indications in Figure 4-18.
- g. Remove short from between INPUT and COMMON posts and set POWER switch to OFF.

VOLTMETER SWITCH SETTINGS			METER INDICATION
RANGE	NULL	VOLTAGE READOUT DIALS A B C D E	
10	1.0	1.0 0 0 0 0	-1.0
1	.1	.1 0 0 0 0	-1.0
1	.01	.0 1 0 0 0	-1.0
Before proceeding, set RANGE switch to 1, NULL switch to .0001, all voltage readout to zero, and null meter by adjusting electronic ZERO control.			
1	.0001	0 0 0 1 0 0	-1.0
100	.1	0 0.1 0 0 0	-1.0
100	.01	0 0.0 1 0 0	-1.0

Figure 4-2. SETTINGS FOR NULL DETECTOR CHECK

4-12. DC DIFFERENTIAL VOLTMETER CHECK. The following procedure checks the accuracy of the instrument when used as a DC Differential Voltmeter. The results of each measurement should be recorded in the Performance Evaluation Record, Figure 4-18, to form a permanent history of instrument performance.

- a. Connect equipment as shown in Figure 4-3 and adjust the equipment to provide dc voltages of 1, 10, 100, and 1000 volts as outlined in paragraph 4-43.
- b. Connect 887A ground post to line ground.
- c. Short INPUT post to COMMON post.
- d. Set 887A ac-dc POLARITY switch to +, RANGE switch to 1, NULL switch to .0001, and all voltage readout dials to 0 (zero).
- e. Null meter by adjusting electronic zero control (R239).
- f. Remove short from between INPUT and COMMON posts.
- g. Set 887A NULL switch to 0.1 and voltage readout dials to 1.000000.
- h. Apply 1 volt dc $\pm(0.001\% + 2 \text{ uv})$ between INPUT and COMMON posts.
- i. Adjust 887A voltage readout dials for zero meter deflection in each successively more sensitive null range. Final voltage readout dial setting should be between .999969 and 1.000031.
- j. Set 887A RANGE switch to 10, NULL switch to 1, and voltage readout dials to 10.00000.
- k. Apply 10 volts dc $\pm 0.001\%$ between INPUT and COMMON posts.

l. Adjust 887A voltage readout dials for zero meter deflection in each successively more sensitive null range. Final voltage readout dial setting should be between 9.99973 and 10.00027.

m. Reverse input connections to 887A and set polarity switch to - (negative). Meter reading should remain within $\pm 5 \text{ uv}$ of indication in step 1.

n. Reverse input connections and set polarity switch to + (positive).

o. Set 887A RANGE switch to 100, NULL switch to 10, and voltage readout dials to 100.0000.

p. Apply 100 volts dc $\pm 0.001\%$ between INPUT and COMMON posts. Note that the voltage dials on the 332A Voltage Standard must be readjusted for a null on 845A Null Detector due to loading of voltmeter on 750A Reference Divider.

q. Adjust 887A voltage readout dials for zero meter deflection in each successively more sensitive null range. Final voltage readout dial setting should be between 99.9974 and 100.0026.

r. Set 887A RANGE switch to 1000, NULL switch to 100, and voltage readout dials to 1000.000.

s. Apply 1000 volts dc $\pm 0.001\%$ between INPUT and COMMON posts. Note that voltage dials on the 332A Voltage Standard must be readjusted for a null on 845A Null Detector because the voltmeter no longer loads 750A Reference Divider.

t. Adjust 887A voltage readout dials for a zero meter deflection in each successively more sensitive null range. Final voltage readout dial setting should be between 999.974 and 1000.026.

u. Disconnect 887A from test equipment.

v. Set 887A ac-dc polarity switch to +, RANGE switch to 1, NULL switch to 0.1, and all voltage readout dials to 0 (zero).

w. Differentially measure the voltage of a standard cell. Final indication should be within $\pm 32 \text{ uv}$ of correct value.

x. Set RANGE switch to 10, NULL switch to 1 and differentially measure the voltage of two standard cells connected in series. Final indication should be within $\pm 66 \text{ uv}$ of correct value.

y. Differentially measure the voltage of three standard cells connected in series. Final indication should be within $\pm 92 \text{ uv}$ of correct value.

z. Set up the necessary equipment to provide voltages of 1.111111, 2.222222, ..., 9.999999 volts dc with an accuracy of $\pm(0.001\% + 2 \text{ uv})$. Proceed as follows:

(1) Set POWER switch to STANDBY/RESET on 332A Voltage Calibrator.

(2) Connect equipment as shown in Figure 4-4.

(3) Set 332A VOLTAGE RANGE to 10 and voltage dials to 10.000000.

(4) Set INPUT switch and OUTPUT switch on 750A Reference Divider to 10.

(5) Set 845A Null Detector to 100 MICROVOLTS.

(6) Set 750A STANDARD CELL VOLTAGE switches to voltage of standard cell.

(7) Set 332A POWER switch to ON.

(8) Adjust 332A voltage dials for a null in each successively more sensitive null range on 845A. Zero 845A as necessary.

(9) Voltages of 1.111111, 2.222222, ..., 9.999999 volts dc are available at the OUTPUT terminals of the 720A Kelvin-Varley Divider when all 720A voltage dials are set to 1, 2, ..., 9 respectively.

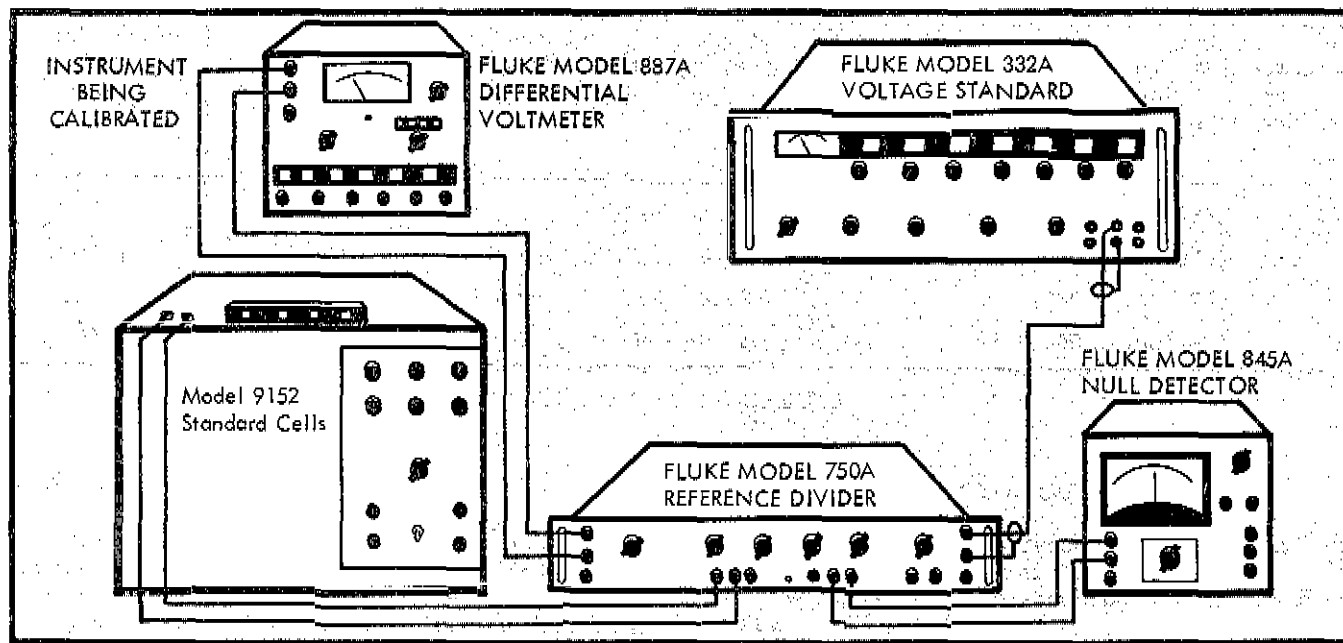

Figure 4-3. EQUIPMENT CONNECTIONS FOR DC CALIBRATION

aa. Set 887A RANGE switch to 10 and NULL switch to .001.

ab. Apply voltages listed in Figure 4-5 between 887A INPUT and COMMON posts, set 887A voltage dials as indicated for applied voltage, and adjust 887A voltage dials for a null on 887A meter. Final voltage dial setting should be within the values listed in Figure 4-5.

4-13. AC CHECK

4-14. The following procedure checks the accuracy of instrument with full input on each ac range at 10

kHz. The results of each measurement should be recorded in the Performance Evaluation Record, Figure 4-18, to form a permanent history of the instrument performance

a. Connect equipment as shown in Figure 4-6 and adjust the equipment to provide 1, 10, 100, and 1000 volts ac rms at 10 kHz such that the average value has an accuracy of 0.02% as instructed in paragraph 4-45.

b. Set polarity switch to AC and voltage readout dials to 10.00000.

c. Complete procedure indicated for each horizontal line of Figure 4-7.

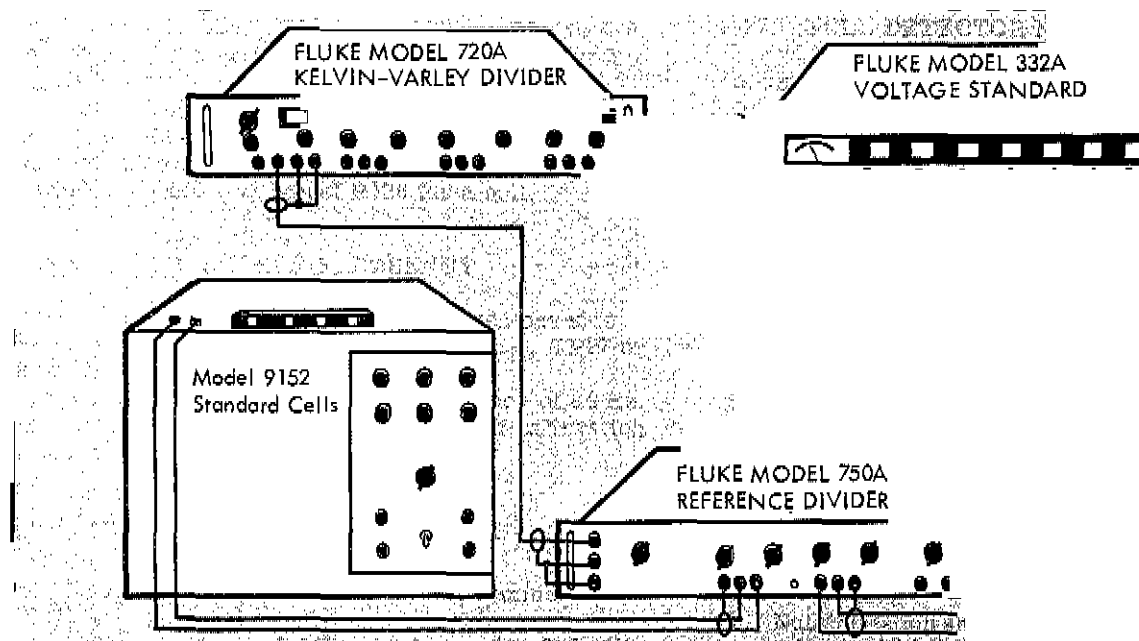

Figure 4-4. REFERENCE SUPPLY AND EXTERNAL KELVIN-VARLEY DIVIDER CHECK SETUP

VOLTAGES APPLIED TO 887A	INITIAL VOLTAGE READOUT DIAL SETTING	FINAL VOLTAGE READOUT DIAL SETTING
1. 1.11111	1. 1.1111	1. 1.1107 to 1.1115
2. 2.22222	2. 2.2222	2. 2.2215 to 2.2229
3. 3.33333	3. 3.3333	3. 3.3323 to 3.3343
4. 4.44444	4. 4.4444	4. 4.4431 to 4.4457
5. 5.55555	5. 5.5555	5. 5.5540 to 5.5570
6. 6.66666	6. 6.6666	6. 6.6648 to 6.6684
7. 7.77777	7. 7.7777	7. 7.7756 to 7.7798
8. 8.88888	8. 8.8888	8. 8.8864 to 8.8892
9. 9.99999	9. 9.9999	9. 9.9972 to 10.0027

Figure 4-5. VOLTAGE READOUT DIAL LIMITS

4-15. PRE-CALIBRATION SERVICE AND ADJUSTMENT

4-16. This procedure contains service checks at critical points within the instrument and a series of minor calibration adjustments to prepare the instrument for final calibration.

4-17. REFERENCE SUPPLY CALIBRATION

- Connect 887A to power line through a variable autotransformer.
- Adjust autotransformer for 115 volts ac output.
- Set POWER switch to LINE OPR with 887AB or to ON with 887A.
- Set NULL switch to TVM.
- Connect a differential voltmeter between circuit common 1, TP1 on schematic and in Figure 4-8, and -18 volt reference supply output, TP26.
- Set up test differential voltmeter to differentially measure -18.0 volts dc.

g. The correct output voltage should be -18.0 ± 0.1 volts. If calibration is necessary, adjust R111 (see Figure 4-9) for a null on test differential voltmeter.

h. Leave test differential voltmeter connected to -18.0 volt reference supply for the next two checks.

4-18. REFERENCE SUPPLY REGULATION

- Adjust autotransformer to vary line voltage from 102 to 128 volts.
- Output of reference supply should not vary more than 800 uv.
- Adjust autotransformer for a line voltage of 115 volts.

4-19. REFERENCE SUPPLY SHIFT (887AB only)

- Turn POWER switch from LINE OPR to BAT OPR.
- Output of reference supply should not vary more than 800 uv.

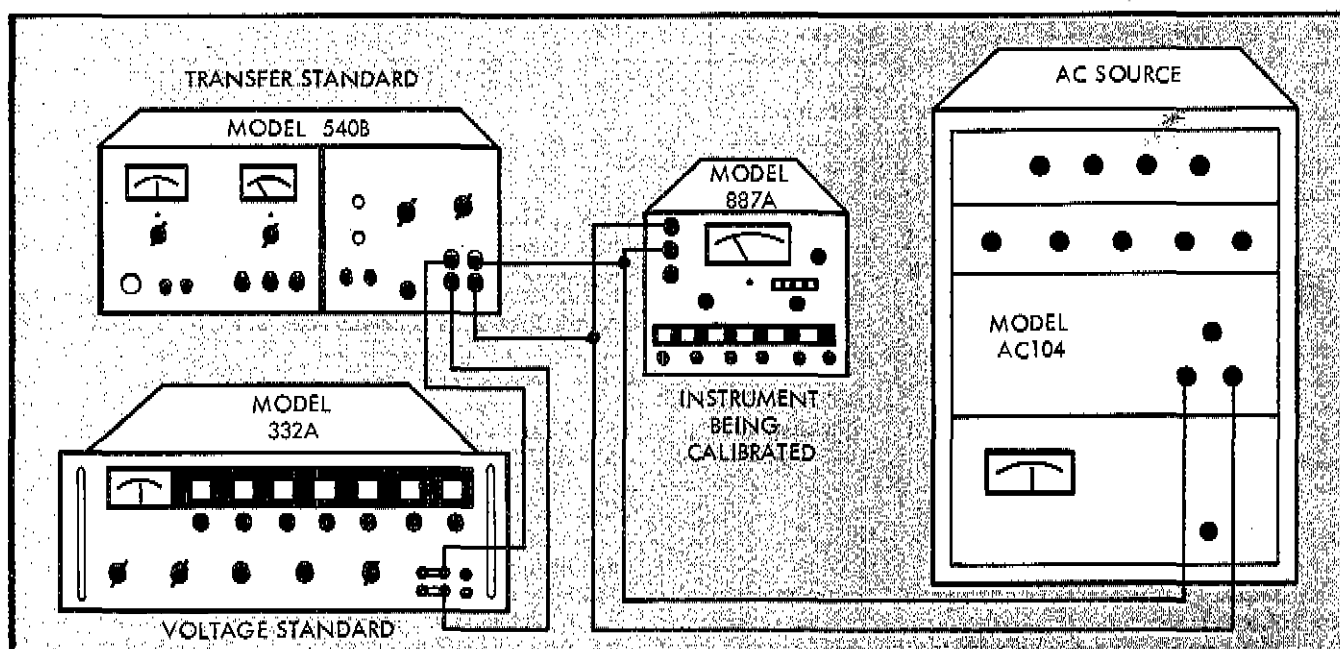

Figure 4-6. EQUIPMENT CONNECTIONS FOR AC CALIBRATION

Set RANGE switch to	Set NULL switch to	Apply the following voltage between INPUT and COMMON posts	Adjust voltage readout dials for zero meter deflection in each successively more sensitive null range. Final voltage readout dial setting should be between
1	TVM	1 vac, 10 KHz, $\pm 0.02\%$.999250 to <u>1.000750</u>
10	TVM	10 vac, 10 KHz, $\pm 0.02\%$	9.99250 to <u>10.00750</u>
100	TVM	100 vac, 10 KHz, $\pm 0.02\%$	99.9250 to <u>100.0750</u>
1000	TVM	1000 vac, 10 KHz, $\pm 0.02\%$	999.000 to <u>1001.000</u>

Figure 4-7. AC CHECKS

4-20. +18 VOLT SUPPLY CALIBRATION

- Connect a differential voltmeter between circuit common 2 and +18 volt supply output, TP29 and TP30 in Figure 4-8.
- Set up test differential voltmeter to differentially measure +18.0 volts dc.
- The correct output voltage should be +18.0 ± 0.1 volts. If calibration is necessary, adjust R539 (see Figure 4-9) for a null on test differential voltmeter.

4-21. +18 VOLT SUPPLY OUTPUT RIPPLE

- Connect an rms voltmeter between circuit common 2 and +18 volt supply output, TP29 and TP30 in Figure 4-8.
- Adjust rms voltmeter controls to measure 200 uv ac.
- Output ripple should be 200 uv or less.

4-22. CHOPPER DRIVE SYMMETRY

- Connect a differential voltmeter across the drive coil of chopper G201, TP27 and TP28 in Figure 4-8.
- Remove shorting link between COMMON and ground post.
- Set up test differential voltmeter to differentially measure 0 ± 50 mv dc.
- The correct voltage should be 0 ± 50 mv. If calibration is necessary, adjust R126 for a null.

4-23. CHOPPER DRIVE FREQUENCY

- Connect an electronic counter between one side of the chopper drive coil and circuit common 1, TP27 or 28, and TP1 in Figure 4-8.
- Set up counter to measure a frequency of 84 Hz.
- Counter should indicate 84 ± 1 Hz. If calibration is necessary, adjust R124.

4-24. NULL DETECTOR FET VOLTAGE

- Measure voltage between circuit common 1 and TP31, with a vtvm.
- Voltage at drain of Q201 should be -10 ± 0.5 volts dc. If calibration is necessary, adjust R208.

4-6

4-25. NULL DETECTOR OUTPUT CHECK

- Measure voltage between circuit common 1 and collector of Q205, TP1 and TP32, with a vtvm.
- Voltage at collector should be between -7 and -10 volts.

4-26. NULL DETECTOR ZERO ADJUSTMENT

- Mechanically zero the meter with the adjustment screw on the front of the meter case. If the instrument is in its case, it must be shut off for at least three minutes prior to this adjustment. If out of its case, another method is to short out the internal panel meter terminals prior to zeroing.
- Turn instrument on and allow a 5 minute warmup period.
- Set RANGE switch to 1, voltage readout dials to zero, polarity to +, and NULL switch to 0.0001.
- Short INPUT post to COMMON post and adjust front panel electronic ZERO control with a screwdriver for zero meter deflection.

4-27. NULL DETECTOR NOISE

- Short INPUT post to COMMON post.
- Random excursions of meter needle should be less than 1 small division peak-to-peak over a 3 second interval.

4-28. NULL DETECTOR OFFSET

- Short INPUT post to COMMON post.
- Remove short while observing meter indication.
- Null indication should not change by more than 2 uv.

4-29. NEGATIVE POLARITY OFFSET

- Turn polarity switch from + to -.
- Null indication should not change by more than 2 uv.

4-30. NULL DETECTOR REGULATION

- Adjust autotransformer to vary line voltage from 102 to 128 volts.
- Null indication should not change by more than 2 uv.
- Adjust autotransformer for a line voltage of 115 volts.

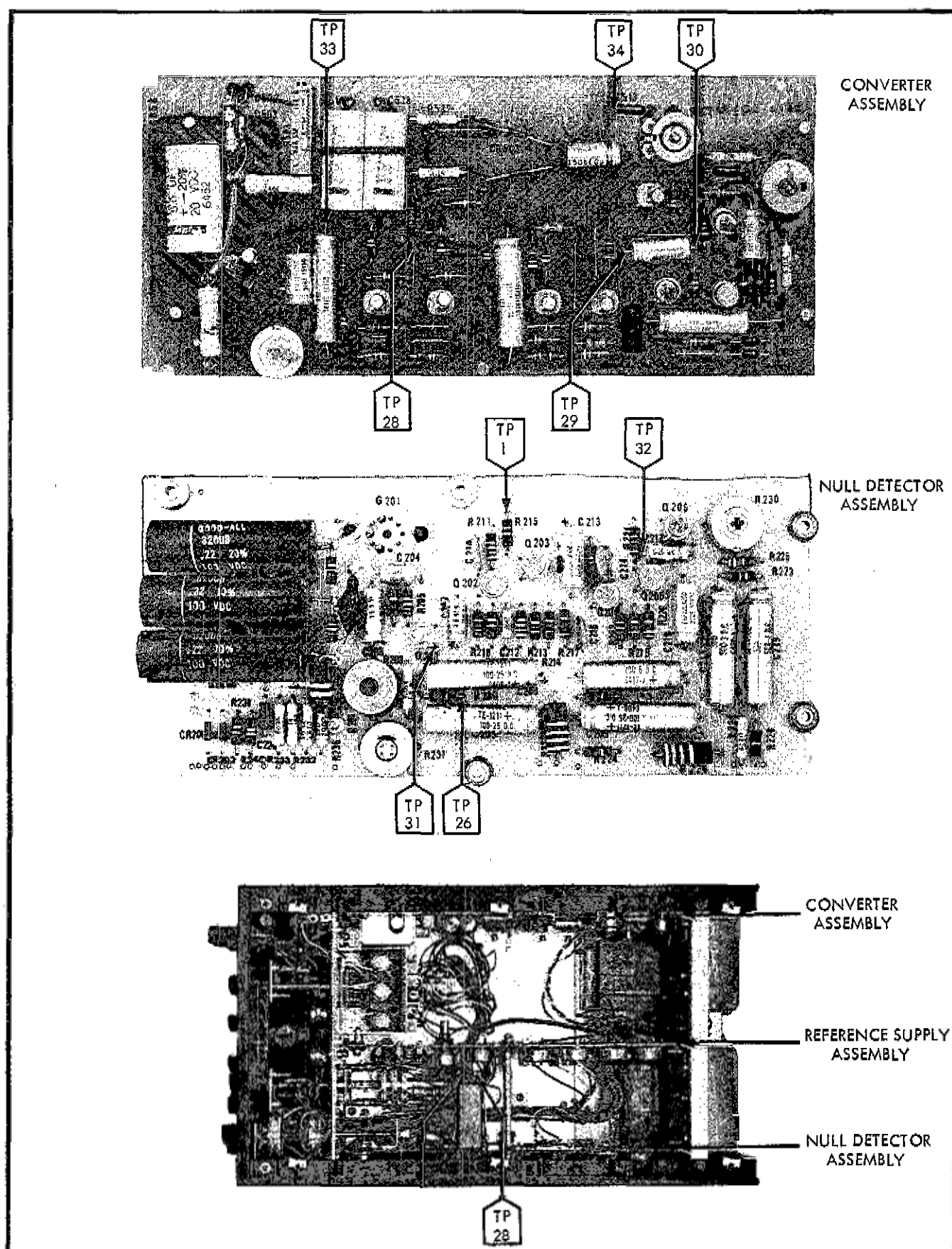

Figure 4-8. CALIBRATION AND MAINTENANCE TEST POINTS

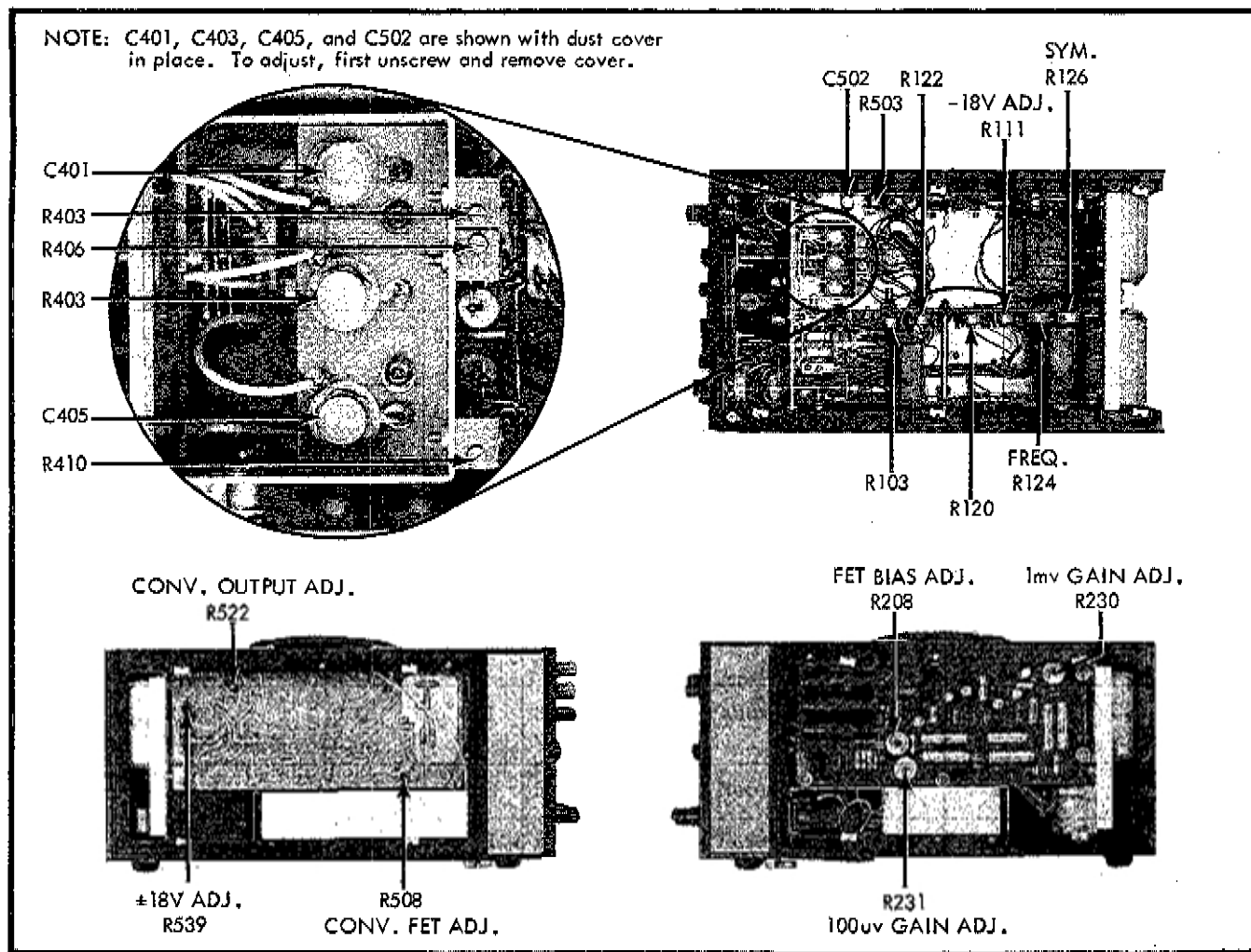

Figure 4-9. LOCATION OF INTERNAL ADJUSTMENTS

4-31. 1 MV GAIN ADJUSTMENT

- Set RANGE switch to 1, NULL switch to TVM, polarity switch to +, and voltage readout dials to zero.
- Apply 1 volt $\pm 0.2\%$ between INPUT and COMMON posts.
- Adjust R230 for full scale deflection (+1.0).

4-32. 100 UV GAIN ADJUSTMENT

- Set RANGE switch to 1, NULL switch to 0.0001, polarity switch to +, and voltage readout dials to zero.
- Short INPUT post to COMMON post.
- Null meter by adjusting electronic ZERO control.
- Set voltage readout dial D to 1 and adjust R231 so that meter indicates full scale (-1).
- Remove short from between INPUT and COMMON posts.

4-33. 100 AND 1000 VOLT NULL SENSITIVITY CHECK

- Set polarity switch to +.
- Short INPUT post to COMMON post.

4-8

- Set switches on voltmeter as shown in Figure 4-10.
- Meter should indicate within 1-1/2 small divisions ($\pm 3\%$ of null range) of the value shown in Figure 4-10.
- Remove short from between INPUT and COMMON posts.

4-34. RECORDER OUTPUT CHECK

- Set RANGE switch to 100, NULL switch to 10, polarity switch to +, and voltage readout dials to 10.0000.
- Short INPUT post to COMMON post.
- Measure voltage between RECORDER OUTPUT posts with the TVM or VTVM mode of a differential voltmeter.
- The output voltage should be at least 20 mv with the AMP ADJ control set for maximum output.
- Remove short from between INPUT and COMMON posts.

4-35. 100 AND 1000 VOLT RANGE CHECK

- Set RANGE switch to 100, NULL switch to TVM polarity switch to +, and voltage readout dials to zero.

VOLTMETER SWITCH SETTINGS			METER INDICATION
RANGE	NULL	VOLTAGE READOUT DIALS A B C D E	
100	10	1 0. 0 0 00	-1.0
100	1	0 1. 0 0 00	-1.0
100	1	0 0. 1 0 00	-1.0
100	01	0 0. 0 1 00	-1.0
1000	100	1 0 0. 0 00	-1.0
1000	10	0 1 0. 0 00	-1.0
1000	1	0 0 1. 0 00	-1.0
1000	1	0 0 0. 1 00	-1.0

Figure 4-10. 100 AND 1000 VOLT NULL SENSITIVITY CHECK

b. Apply 100 volts $\pm 0.2\%$ between INPUT and COMMON posts.

c. Meter should indicate within 1 small division of full scale (+1).

d. Set RANGE switch to 1000, meter should indicate within 1 small division of 1/10 of full scale (+0.1).

4-36. POLARITY REVERSAL CHECK

a. Differentially measure the voltage of a standard cell in the 1 volt range with and without a 100K resistor connected in series in both the positive and negative polarity.

b. All four measurements should agree within 5 uv.

4-37. COMMON MODE CHECK

a. Differentially measure the voltage of a standard cell in the 1 volt range and in the + polarity.

b. Apply approximately 500 dc volts between COMMON and ground posts.

c. After 3 minutes, note change in standard cell reading. The change should not be more than 25 uv.

4-38. CONVERTER FET VOLTAGE

a. Measure voltage between circuit common 2 and drain of Q501, TP29 and TP31 in Figure 4-8, with a vtvm.

b. Voltage drain of Q501 should be $+11.0 \pm 0.5$ volts. If calibration is necessary, adjust R508.

4-39. CONVERTER OUTPUT VOLTAGE

a. Measure voltage between circuit common 2 and collector of Q506, TP29 and TP34, with a vtvm.

b. Voltage at collector of Q506 should be $9.0 + 0.5/-1.5$ volts. If calibration is necessary, adjust R522.

4-40. AC SENSITIVITY CHECK

a. Connect equipment as shown in Figure 4-6 and adjust the equipment to provide 1, 10, 100 and 1000 volts ac rms at 10 kHz such that the average value has an accuracy of 0.02% as instructed in paragraph 4-45.

b. Set polarity switch to AC and voltage readout dials to 10.00000.

c. Complete procedure indicated for each horizontal line of Figure 4-7.

4-41. CALIBRATION

4-42. DC CALIBRATION

4-43. The following procedures should be performed with the instrument and test equipment in the temperature range of 72° F to 75° F with the relative humidity not more than 70%. DC calibration voltages must be accurate to $\pm(0.001\% + 2 \text{ uv})$. Connect the test equipment as shown in Figure 4-3 and adjust the controls as follows:

a. Turn on all of the equipment and allow it to warm up for at least 1/2 hour.

CAUTION!

Make sure 332A POWER switch is set to STANDBY/RESET.

b. Set the STANDARD CELL VOLTAGE switches on the Model 750A Reference Divider to voltage of standard cell.

c. Set the INPUT VOLTAGE switch on the Model 750A Reference Divider to 1000V.

d. Set the Model 332A output voltage dials for an output of 1000 volts.

e. Set the Model 845A Null Detector RANGE switch to 100 uv after zeroing the meter with the ZERO control.

f. Set the Model 332A POWER switch to ON.

g. Adjust the Model 332A output voltage dials for a null in each successively more sensitive position of the 845A Null Detector RANGE switch.

h. Output voltages of 0.1, 0.5, 1, 5, 10, 100, and 1000 volts are available at the output terminals of the Model 750A Reference Divider. During the calibration procedure, periodically check the Model 845A for a null indication and adjust the Model 332A output voltage if necessary.

4-44. The 13 steps in the table of Figure 4-11 are used to perform the final dc calibration. If adjustments are necessary in Steps 1, 3, or 4, the NULL switch should be returned to the least sensitive position and advanced to successively more sensitive positions while adjusting the indicated control for a null indication on the meter. In all other steps, the desired meter indication is zero.

4-45. AC CALIBRATION

4-46. The following procedure should be performed at a temperature from 72° F to 75° F and a relative humidity of 70% or less.

a. Connect all test equipment as shown in Figure 4-6.
b. Turn on all test equipment and allow it to warmup for at least 1/2 hour.

c. Set 332A Voltage Standard for an output of 1 volt.

d. Null galvanometer of 540B Transfer Standard by adjusting internal reference supply of 540B.

e. Apply output of AC104 AC Source at desired frequency to 540B and null galvanometer by adjusting ac source voltage.

STEP	FUNCTION	MODEL 887A CONTROL SETTINGS			MODEL 887A INPUT CONNECTIONS	TOLERANCE	ADJ.
		RANGE	NULL	READOUT			
1	CALIBRATE 10V Range	10	0.001	<u>10.00000</u>	10V Reference Divider	±100 uv	R120
2	CHECK <u>9.999100</u>	10	0.001	<u>9.999100</u>	10V Reference Divider	±100 uv	
3	CALIBRATE 1V Range	1	0.0001	<u>1.000000</u>	1V Reference Divider	±10 uv	R122
4	CALIBRATE 100V Range	100	0.01	<u>100.0000</u>	100V Reference Divider	±1 mv	R103
5	CHECK 1000V Range	1000	0.1	<u>1000.000</u>	1000V Reference Divider	±10 mv	
6	CHECK Standard Cell	10	0.001	St. Cell voltage	1 Standard cell	±18 uv	
7	CHECK Standard Cell	1	0.0001	St. Cell voltage	1 Standard cell	±10 uv	
8	CHECK 2 Standard Cells	10	0.001	2 cell voltage	2 Standard cells	±30 uv	
9	CHECK 3 Standard Cells	10	0.001	3 cell voltage	3 Standard cells	±45 uv	
10	CHECK 5V	10	0.001	<u>5.00000</u>	5V Reference divider	±75 uv	
11	CHECK 5V BATT OPR	10	0.001	<u>5.00000</u>	5V Reference divider	±75 uv	
12	CHECK 0.5V	1	0.0001	<u>0.50000</u>	0.5V Reference divider	±10 uv	
13	CHECK 0.1V	1	0.0001	<u>0.10000</u>	0.1 Reference divider	±4 uv	

Figure 4-11. DC CALIBRATION ADJUSTMENTS AND TOLERANCES

f. Apply output of ac source to input of 887A being calibrated.

g. Repeat steps d and e for each calibration voltage and frequency required.

4-47. The 31 steps of Figure 4-12 are used to perform the final ac calibration. It should be noted that odd harmonic distortion will cause a maximum error equal to the percent harmonic distortion divided by the order of the harmonic. For example, third harmonic distortion of 0.03% will cause an error between -0.01% and +0.01% depending on the phase relationship. If excessive harmonic distortion is suspected, check the ac source with a wave analyzer.

4-48. KELVIN-VARLEY DIVIDER EVALUATION

4-49. Kelvin-Varley evaluation requires that connections to the Kelvin-Varley divider be made inside the instrument. Also, Kelvin-Varley evaluation takes a considerable amount of time to perform. Therefore, this check should be performed only if the dc differential voltmeter check (paragraph 4-12) indicates there is a

4-10

problem or if the Kelvin-Varley has been calibrated (paragraph 4-50). Proceed as follows:

- Disconnect 887A from power line.
- Set POWER switch to OFF and NULL switch to TVM.
- Remove bottom panel, top-back panel, side panels, and shield protecting polarity switch on left side on instrument. This shield is held in place by one screw accessible from the top of the instrument.
- With the aid of Figure 4-14, locate high input (white wire from TP13 on Kelvin-Varley board to polarity switch), high output (wiper terminal of R386 where brown and yellow wire are connected), and input-output common (TP1 on Kelvin-Varley board) of Kelvin-Varley divider.

CAUTION!

Make sure 332A POWER switch is set to STANDBY/RESET.

- Unsolder high input wire (white) from polarity switch and connect lead A of Figure 4-13 to high input, lead B to high output, and lead C to input-output common.

STEP	FUNCTION	MODEL 887A CONTROL SETTINGS			MODEL 887A INPUT VOLTAGE	TOLERANCE	ADJUST
		RANGE	NULL	READOUT			
1	CALIBRATE 1V 400 Hz	1	0.001	<u>1.000000</u>	1V 400 Hz	0 to 1 Major Divisions (+0.01) of null	R503
2	CALIBRATE 1V 20 kHz	1	0.001	<u>1.000000</u>	1V 20 kHz	± 1 major division (±0.01%) of null	C502
3	CHECK 1V 400 Hz	1	0.001	<u>1.000000</u>	1V 400 Hz	If within 0 to 1 major divisions go on to step 4. If not, go back to step 1.	
4	CHECK 1V 5 kHz	1	0.001	<u>1.000000</u>	1V 5 kHz	± 1 major division (±0.01%) of null	
5	CHECK 1V 10 kHz	1	0.001	<u>1.000000</u>	1V 10 kHz	± 1.5 major divisions (±0.015%) of null	
6	CHECK 1V 50 kHz	1	0.01	<u>1.000000</u>	1V 50 kHz	±3 major divisions (±0.3%) of null	
7	CHECK 1V 100 kHz	1	0.01	<u>1.000000</u>	1V 100 kHz	±5 major divisions (±0.5%) of null	
8	CHECK 1V 20 Hz	1	0.001	<u>1.000000</u>	1V 20 Hz	±3 major divisions (±0.03%) of null	
9	CHECK 0.1V 400 Hz	1	0.001	<u>0.100000</u>	0.1V 400 Hz	±5 major divisions (±0.05%) of null	
10	CHECK 0.1V 10 kHz	1	0.001	<u>0.100000</u>	0.1V 10 kHz	±0.5 major divisions (±0.05%) of null	
11	CHECK 1 mv 10 kHz	1	0.001	<u>0.001000</u>	0.001V 10 kHz	±1 small division (±2%) of null	
12	CALIBRATE 10V 400 Hz	10	0.01	<u>10.00000</u>	10V 400 Hz	0 to 1 major division (+0.01%) of null	R403
13	CALIBRATE 10V 20 kHz	10	0.01	<u>10.00000</u>	10V 20 kHz	±1 major division (±0.01%) of null	C401
14	CHECK 10V 400 Hz	10	0.01	<u>10.00000</u>	10V 400 Hz	If within 0 to 1 major division, go on to step 15. If not go back to step 12.	
15	CHECK 10V 5 kHz	10	0.01	<u>10.00000</u>	10V 5 kHz	±1.5 major divisions (±0.015%) of null.	
16	CHECK 10V 10 kHz	10	0.01	<u>10.00000</u>	10V 10 kHz	±2 major divisions, (±0.02%) of null	
17	CHECK 10V 50 kHz	10	0.1	<u>10.00000</u>	10V 50 kHz	±3 major divisions (±0.3%) of null	
18	CHECK 10V 100 kHz	10	0.1	<u>10.00000</u>	10V 100 kHz	±7 major divisions (±0.7%) of null	

Figure 4-12. AC CALIBRATION ADJUSTMENTS AND TOLERANCES (Sheet 1 of 2)

STEP	FUNCTION	MODEL 887A CONTROL SETTINGS			MODEL 887A INPUT VOLTAGE	TOLERANCE	ADJUST
		RANGE	NULL	READOUT			
19	CALIBRATE 100V 400 Hz	100	0.1	<u>100.0000</u>	100V 400 Hz	0 to 1 major division (+0.01%) of null	R406
20	CALIBRATE 100V 20 kHz	100	0.1	<u>100.0000</u>	100V 20 kHz	±1 major division (±0.01%) of null	C403
21	CHECK 100V 400 Hz	100	0.1	<u>100.0000</u>	100V 400 Hz	If within 0 to 1 major division, go on to step 22. If not, go back to step 19.	
22	CHECK 100V 5 kHz	100	0.1	<u>100.0000</u>	100V 5 kHz	±1.5 major divisions (±0.015%) of null	
23	CHECK 100V 10 kHz	100	0.1	<u>100.0000</u>	100V 10 kHz	±2 major divisions (±0.02%) of null	
24	CHECK 100V 50 kHz	100	0.1	<u>100.0000</u>	100V 50 kHz	±4 major divisions (±0.4%) of null	
25	CHECK 100V 100 kHz	100	1.0	<u>100.0000</u>	100V 100 kHz	±7 major divisions (±0.7%) of null	
26	CALIBRATE 500V 400 kHz	1000	1.0	500.000	500V 400 kHz	0 to 1/2 major divi- sions (+0.01%) of null	R410
27	CALIBRATE 500V 10 kHz	1000	1.0	500.000	500V 10 kHz	±1/2 major division (±0.01%) of null	C405
28	CHECK 500V 400 Hz	1000	1.0	500.000	500V 400 kHz	If within 0 to 1/2 major division go on to step 29. If not, go back to step 26.	
29	CHECK 500V 5 kHz	1000	1.0	500.000	500V 5 kHz	±1/2 of major division (±0.01%) of null	
30	CHECK 500V 20 kHz	1000	1.0	500.000	500V 20 kHz	±3 major divisions (±0.06%) of null	
31	CHECK 1000V 400 Hz	1000	1.0	<u>1000.000</u>	1000V 400 Hz	±3 major divisions (±0.03%) of null	

Figure 4-12. AC CALIBRATION ADJUSTMENTS AND TOLERANCES (Sheet 2 of 2)

f. Turn all equipment on and allow it to warmup to equilibrium temperature (about 1/2 hour).

g. Set voltage dials on 332A Voltage Standard for an output of 33.0 volts dc.

h. Set 887A voltage readout dials to 000000 and 720A Kelvin-Varley Divider dials to 0000000.

i. Set 845A Null Detector to 100 MICROVOLTS.

j. Set function switch to VOLTAGE OFF on 721A Lead Compensator.

k. Zero 845A Null Detector.

l. Set function switch to $R_S > R_X$ on 721A Lead Compensator.

m. Adjust LOW BALANCE controls on 721A for a null on 845A. It may be necessary to temporarily reduce sensitivity of 845A to find null point on LOW BALANCE

controls.

n. Set 887A voltage dials to 10999100 and 720A Kelvin-Varley dials to 109999910.

o. Set function switch to VOLTAGE OFF on 721A Lead Compensator.

p. Zero 845A Null Detector.

q. Set function switch to $R_S > R_X$ on 721A Lead Compensator.

r. Adjust HIGH BALANCE controls on 721A for a null on 845A. It may be necessary to temporarily reduce sensitivity of 845A to find null point on HIGH BALANCE controls.

s. Set 845A Null Detector to 300 MICROVOLTS and change to 100 MICROVOLTS and 30 MICROVOLTS as required.

t. Set 887A voltage readout dials and 720A Kelvin-Varley Divider dials to first positions shown in Figure 4-15.

u. Set function switch to VOLTAGE OFF on 721A Lead Compensator.

v. Zero 845A Null Detector.

w. Set function switch to $R_S > R_X$ on 721A Lead Compensator. The 845A Null Detector indication should be equal to or less than the listed deviation.

x. Repeat steps u through w for remaining switch positions shown in Figure 4-15. If Kelvin-Varley divider is out of tolerance between settings of 1000000 and 0999100, readjust as set forth in paragraph 4-49. If a resistor-trimmer combination of the first deck can not be adjusted for a null during calibration, a resistor is defective and must be replaced. If Kelvin-Varley divider is out of tolerance for remaining settings, make sure padding trimmers are adjusted correctly (paragraph 4-49) before attempting to replace a resistor.

y. Resolder high input wire to polarity switch.

4-50. KELVIN-VARLEY DIVIDER CALIBRATION

4-51. The Kelvin-Varley divider should be calibrated only after a resistor has been replaced or after the Kelvin-Varley divider evaluation (paragraph 4-47) indicates that the Kelvin-Varley divider is out of tolerance. In this procedure circuit test points are identified by number. This number appears on the circuit board adjacent to the test point. Proceed as follows:

- Disconnect 887A from power line.
- Set POWER switch to OFF and NULL switch to TVM.
- Remove bottom and side covers of instrument.

d. Open jumpers marked with a U, V, W, X, Y, and Z (see Figure 4-14) by unsoldering one end and pulling it loose. Also unsolder high input of Kelvin-Varley divider (white wire from Kelvin-Varley board to polarity switch).

e. Connect equipment as shown in Figure 4-13.

f. Turn on all equipment and allow it to warmup to equilibrium temperature (about 1/2 hour).

CAUTION!

Do not allow power supply voltage to exceed 40 volts as damage to the Kelvin-Varley resistors may result.

g. Adjust 332A Voltage Calibrator for an output of 4 volts dc.

h. Connect lead A and C of Figure 4-13 to TP14 and TP16 of Kelvin-Varley board respectively.

i. Eliminate errors due to resistance of leads and connections as follows:

- Set 845A Null Detector to 30 MICROVOLTS.
- Set 720A Kelvin-Varley Divider dials to 0000000.
- Connect point B of Figure 4-13 to test point that point C is connected to.
- Set function switch to VOLTAGE OFF on 721A Lead Compensator.
- Adjust ZERO control to null meter on 845A Null Detector.
- Set function switch to $R_S > R_X$ on 721A Lead Compensator.
- Adjust LOW BALANCE controls on 721A Lead Compensator for a null on 845A. It may be necessary to temporarily reduce sensitivity of 845A to find null point on LOW BALANCE controls.

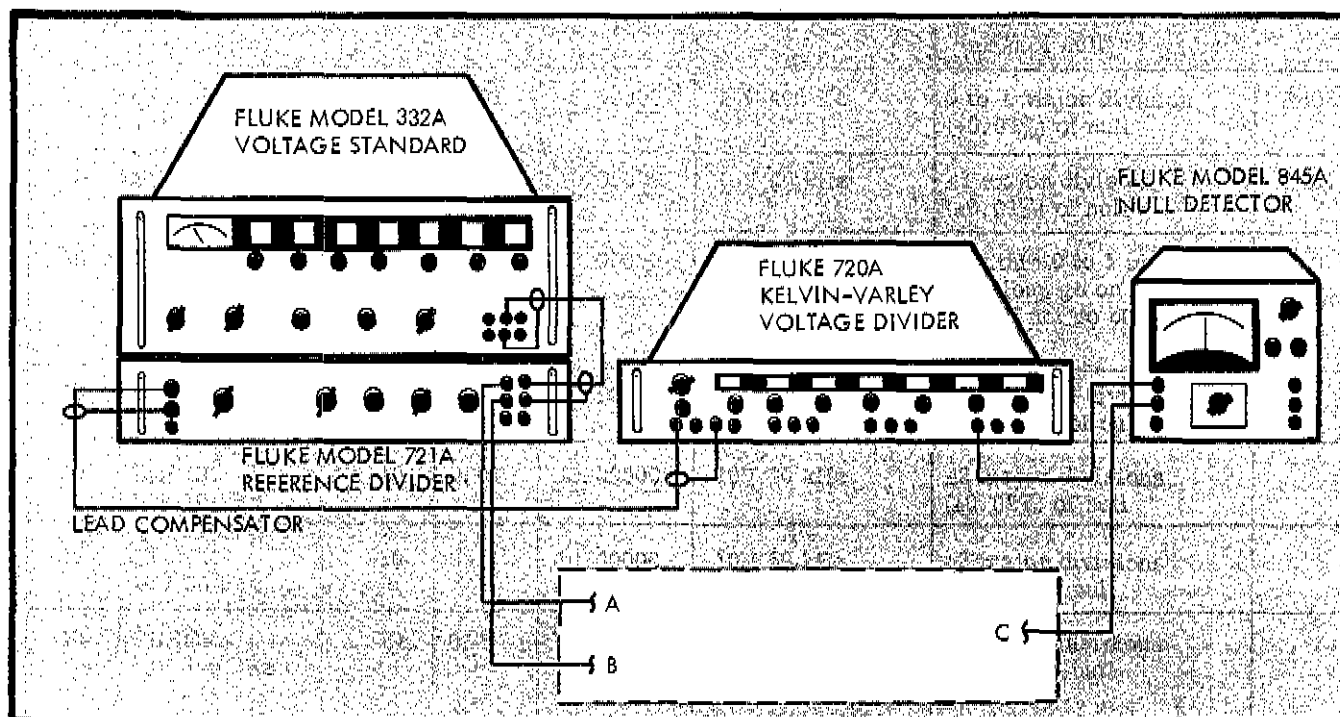

Figure 4-13. EQUIPMENT CONNECTIONS FOR EVALUATING AND CALIBRATING THE INTERNAL KELVIN-VARLEY DIVIDER

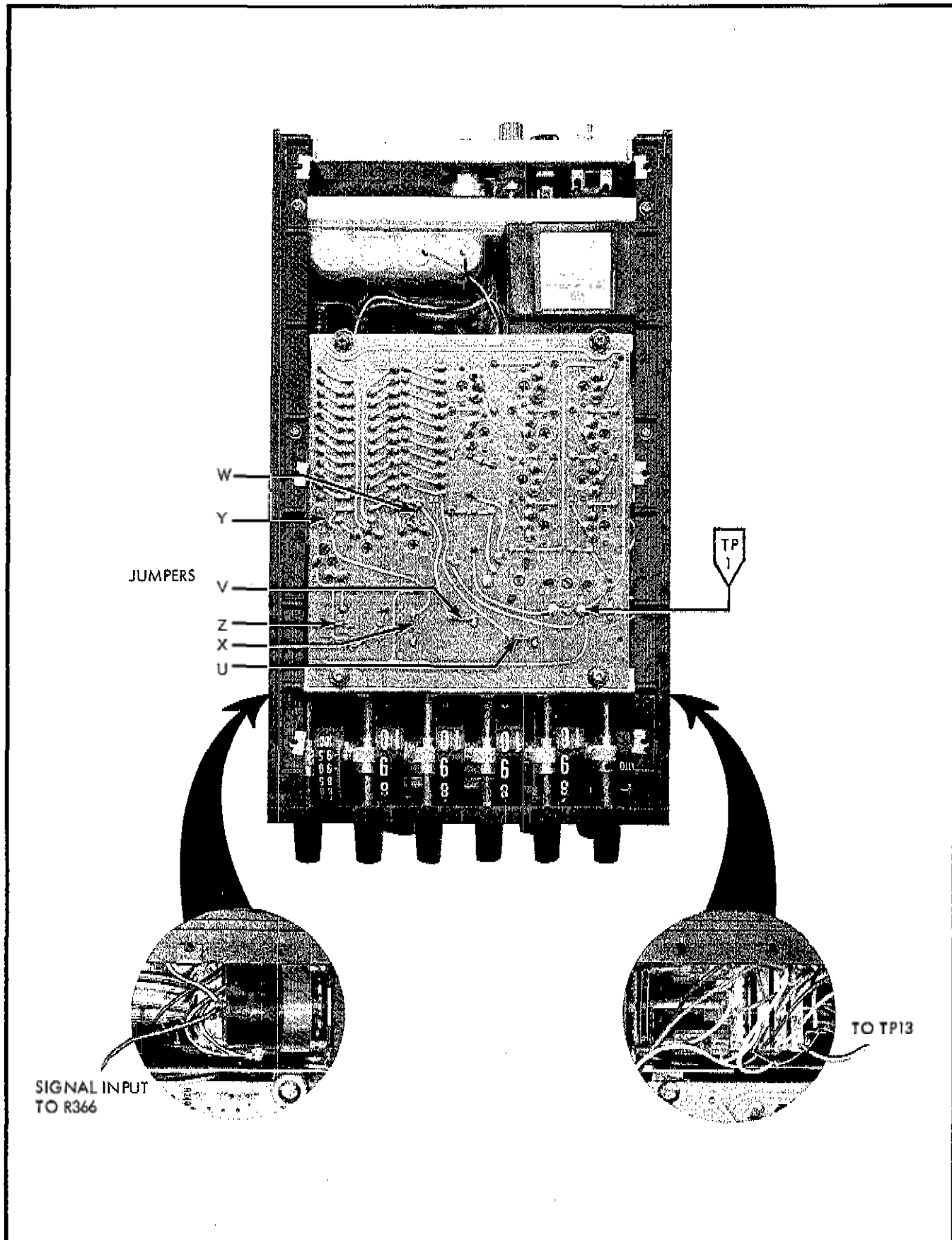

Figure 4-14. KELVIN-VARLEY CONNECTIONS

887A Voltage Dial Settings	Standard Divider Settings	Maximum Deviation for an Input of 33.0 vdc (± microvolts)	887A Voltage Dial Settings	Standard Divider Settings	Maximum Deviation for an Input of 33.0 vdc (± microvolts)
1000000	10000000	360	007000	0070000	36
9999100	10000000	360	0069100	0070000	36
900000	9000000	324	006000	0060000	36
8999100	9000000	324	0059100	0060000	36
800000	8000000	288	005000	0050000	36
7999100	8000000	288	0049100	0050000	36
700000	7000000	252	004000	0040000	36
6999100	7000000	252	0039100	0040000	36
600000	6000000	216	003000	0030000	36
5999100	6000000	216	0029100	0030000	36
500000	5000000	180	002000	0020000	36
4999100	5000000	180	0019100	0020000	36
400000	4000000	144	001000	0010000	36
3999100	4000000	144	0009100	0010000	36
300000	3000000	108	000900	0009000	36
2999100	3000000	108	0008100	0009000	36
200000	2000000	72	000800	0008000	36
1999100	2000000	72	0007100	0008000	36
100000	1000000	36	000700	0007000	36
0999100	1000000	36	0006100	0007000	36
090000	0900000	36	000600	0006000	36
0899100	0900000	36	0005100	0006000	36
080000	0800000	36	000500	0005000	36
0799100	0800000	36	0004100	0005000	36
070000	0700000	36	000400	0004000	36
0699100	0700000	36	0003100	0004000	36
060000	0600000	36	000300	0003000	36
0599100	0600000	36	0002100	0003000	36
050000	0500000	36	000200	0002000	36
0499100	0500000	36	0001100	0002000	36
040000	0400000	36	000100	0001000	36
0399100	0400000	36	0000100	0001000	36
030000	0300000	36	000090	0000900	36
0299100	0300000	36	000080	0000800	36
020000	0200000	36	000070	0000700	36
0199100	0200000	36	000060	0000600	36
010000	0100000	36	000050	0000500	36
0099100	0100000	36	000040	0000400	36
009000	0090000	36	000030	0000300	36
0089100	0090000	36	000020	0000200	36
008000	0080000	36	000010	0000100	36
0079100	0080000	36	000000	0000000	0

Figure 4-15. KELVIN-VARLEY DIVIDER ERROR LIMITS

- (8) Set 721A Kelvin-Varley Divider dials to 10000000.
- (9) Connect point B of Figure 4-13 to test point that point A is connected to.
- (10) Repeat steps (4), (5), and (8).
- (11) Adjust HIGH BALANCE controls on 721A for a null on 845A. It may be necessary to temporarily reduce sensitivity of 845A to find null point on HIGH BALANCE controls.
 - j. Set voltage dial E to 50.
 - k. Connect point B of Figure 4-13 to TP15.
 - l. Set 720A Kelvin-Varley Divider to 5000000.
 - m. Eliminate error due to thermal voltages as follows:

- (1) Set function switch to VOLTAGE OFF on 721A Lead Compensator.
- (2) Set 845A Null Detector to 30 MICROVOLTS and adjust ZERO control to null meter.
- (3) Set function switch to $R_S > R_X$ on 721A Lead Compensator.
 - n. Set 845A Null Detector to 1 MILLIVOLT.
 - o. Adjust R364 (at point P) to within ±200 microvolts of null.
 - p. Reconnect points A and C to TP17 and TP18 respectively.
 - q. Solder down jumpers Z and Y.

- r. Repeat step i.
- s. Connect point B to TP19.
- t. Repeat steps m and n.
- u. Adjust R351 (at point N) to within ± 50 microvolts of null.
- v. Reconnect points A and C to TP20 and TP 21 respectively.
- w. Solder down jumper X and W.
- x. Repeat step i.
- y. Connect point B to TP22.
- z. Repeat steps m and n.
- aa. Adjust R338 (at point M) to within ± 20 microvolts of null.
- ab. Adjust 332A Voltage Calibrator for an output of 18 volts dc.
- ac. Reconnect points A and C to TP23 and TP24 respectively.
- ad. Solder down jumper V.
- ae. Repeat step i.
- af. Connect point B to TP25.
- ag. Set 720A Kelvin-Varley Divider dials to 6666667.
- ah. Make adjustments as given in each horizontal line of Figure 4-16.
- ai. Solder down jumper U and high input wire of Kelvin-Varley divider.
- aj. Recoat Kelvin-Varley board with Epocast 8267.
- ak. Check accuracy of Kelvin-Varley divider using procedure of paragraph 4-47.

4-53. STABILITY EVALUATION

4-54. The stability evaluation is a three-step procedure intended to measure the instruments stability with respect to time. The evaluation technique is to measure certain performance characteristics at three different times while observing test results for out-of-tolerance indications. To evaluate the dc stability, proceed as follows:

a. Turn the instrument off for at least two hours then turn it on and allow it to warm up for 15 minutes.

(1) In the 1 volt range, short the input, and switch to the 100 uv null sensitivity. If the meter indicates within ± 3 uv of null it is in calibration. Readjust the ZERO control for null.

(2) Measure a standard cell in the 1 volt range. The reading must be within 10 uv of the standard cell voltage.

b. The second and third readings of 1 and 2 above should be made within 48 to 96 hours. The instrument should be left on, AB models in the LINE OPR mode.

c. The three readings of step a (1) should all be within ± 3 uv of zero. If the readings were greater than ± 3 uv, check the Null Detector input for thermals and voltaics.

d. The largest difference between any two of the three standard cell readings in step a (2) must be less than 12 uv. If the difference is greater than 6 uv but less than 12 uv, set the Kelvin-Varley readouts to the average of the two outside readings. Apply the standard cell voltage to the input and adjust R120 for a null. If the difference is greater than 12 uv, it is likely that the reference supply or the reference zener is unstable.

4-55. The ac stability check should be made with the equipment shown in Figure 4-6. The procedure is the same as for the dc stability evaluation. That is, measure the performance at three different times, comparing the results for excessive drift.

a. Check 1 v, 5 kHz, it should read within ± 2 major divisions ($\pm 0.2\%$).

b. Check 10 v, 5 kHz, it should read within ± 2 major divisions ($\pm 0.2\%$).

c. Check 100 v, 5 kHz, it should read within ± 2 major divisions ($\pm 0.2\%$).

d. Check 500 v, 5 kHz, it should read within ± 1 major division. ($\pm 0.2\%$)

Set Voltage Dial A To	Short Test Points	Eliminate Thermal Voltage Errors as in step m	Set 845A Null Detector to 100 microvolts	Adjust Control to Within ± 15 microvolts of Null at Point	Remove Short from Between
0	2 to 3	"	"	R301 A	2 and 3
0	1 to 2	"	"	R304 B	1 and 2
2	4 to 5	"	"	R307 C	4 and 5
2	3 to 4	"	"	R309 D	3 and 4
4	6 to 7	"	"	R311 E	6 and 7
4	5 to 6	"	"	R313 F	5 and 6
6	8 to 9	"	"	R315 G	8 and 9
6	7 to 8	"	"	R317 H	7 and 8
8	10 to 11	"	"	R319 I	10 and 11
8	9 to 10	"	"	R321 J	9 and 10
10	12 to 13	"	"	R323 K	12 and 13
10	11 to 12	"	"	R325 L	11 and 12

Figure 4-16. KELVIN-VARLEY "A" DECK ADJUSTMENT

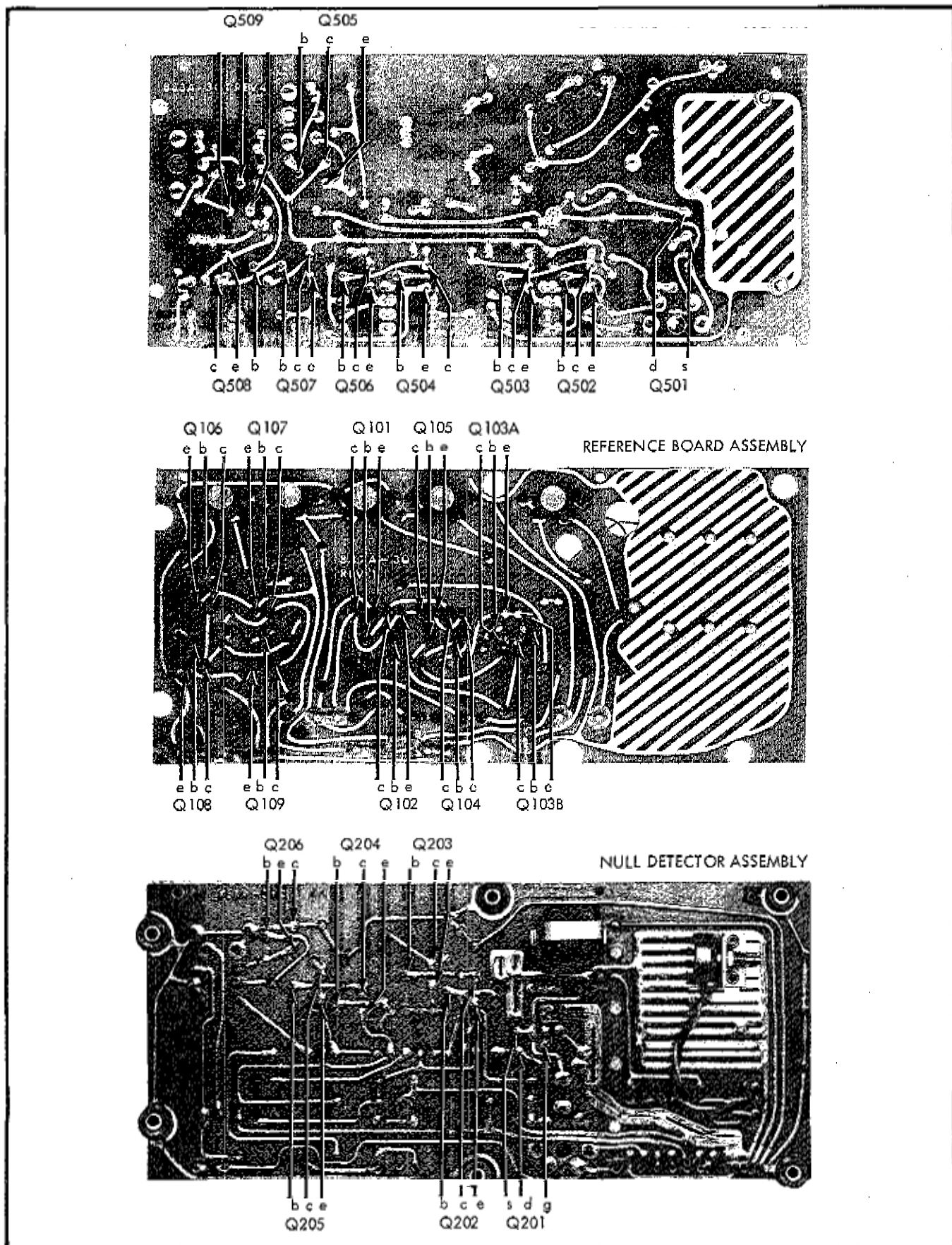

Figure 4-17. LOCATION OF TRANSISTOR TERMINALS

PROCEDURE STEP AND FUNCTION TESTED	TOLERANCES	MEASURED VALUES					
		FIRST CHECK	SECOND CHECK	THIRD CHECK	FOURTH CHECK	FIFTH CHECK	SIXTH CHECK
DATE	---						
4-10. DC CHECKS	---						
4-11. NULL DET CHECK	---						
4-11f. Rng 10 Null 1	-0.97 to -1.03						
4-11f. Rng 1 Null 0.1	-0.97 to -1.03						
4-11f. Rng 1 Null 0.01	-0.97 to -1.03						
4-11f. Rng 1 Null 0.001	-0.97 to -1.03						
4-11f. Rng 100 Null 0.1	-0.97 to -1.03						
4-11f. Rng 100 Null 0.01	-0.97 to -1.03						
4-12. DC DIFF. VM. CHK.	---						
4-12i. 1 Volt Range	.999969 to 1.000031						
4-12i. 10 Volt Range	9.99973 to 10.00027						
4-12m. Polarity Reversal	±5 uv						
4-12q. 100 Volt Range	99.9974 to 100.0026						
4-12t. 1000 Volt Range	999.974 to 1000.026						
4-12w. One Standard Cell	±32 uv						
4-12x. Two Standard Cells	±66 uv						
4-12y. Three Standard Cells	±92 uv						
4-12ab. K-V Check	1.11107 to 1.11115						
4-12ab. K-V Check	2.22215 to 2.22229						
4-12ab. K-V Check	3.33323 to 3.33343						
4-12ab. K-V Check	4.44431 to 4.44457						
4-12ab. K-V Check	5.55540 to 5.55570						
4-12ab. K-V Check	6.66648 to 6.66684						
4-12ab. K-V Check	7.77756 to 7.77798						
4-12ab. K-V Check	8.88864 to 8.88912						
4-12ab. K-V Check	9.99972 to 10.00027						
4-13. AC CHECK	---						
4-13c. 1 vac, 10 kHz	.999250 to 1.000750						
4-13c. 10 vac, 10 kHz	9.99250 to 10.00750						
4-13c. 100 vac, 10 kHz	99.9250 to 100.0750						
4-13c. 1000 vac, 10 kHz	999.000 to 1001.000						
<p>This table is intended to provide a permanent record of the instruments performance. The procedure for evaluation performance is described in paragraph 4-9. The suggested cyclic period of evaluation is six months, although shorter intervals are frequently more desirable.</p>							

Figure 4-18. PERFORMANCE EVALUATION RECORD

SECTION V

LIST OF REPLACEABLE PARTS

5-1. INTRODUCTION

5-2. This section contains complete descriptions of those parts one might normally expect to replace during the life of the instrument. The first listing is a breakdown of all of the major assemblies in the instrument. Subsequent listings itemize the components in each assembly. Every listing is accompanied by an illustration identifying each component in the listing. Assemblies and subassemblies are identified in both the list and the illustration with a reference designation beginning with the letter A, (e.g., A1, A100, A201, etc.). Components are identified by the schematic diagram reference designation (e.g., R1, C107, DS1). Parts not appearing on the schematic diagram are identified by a number of the same series as the other parts of the assembly (e.g., 8, 103, 209).

5-3. COLUMNAR INFORMATION

a. The REF DESIG column indexes the item description to the associated illustration. In general the reference designations are listed in alpha-numeric order. Subassemblies of minor proportions are sometimes listed with the assembly of which they are a part. In this case, the reference designations for the components of the subassembly may appear out of order.

b. The DESCRIPTION column describes the salient characteristics of the component. Indentation of the item description indicates the relationship to other assemblies, components, etc. See Abbreviations and Symbols, paragraph 5-7, next page.

c. The ten-digit part number by which the item is identified at the John Fluke Mfg. Co. is listed in the FLUKE PART NO column. Use this number when ordering parts from the factory or authorized representatives.

d. The Federal Supply Code for the item manufacturer is listed in the MFR column. An abbreviated list of Federal Supply Codes is included in the Appendix.

e. The part number which uniquely identifies the item to the original manufacturer is listed in the MFR PART NO column. If a component must be ordered by description, the type number is listed.

f. The TOT QTY column lists the total quantity of the item used in the instrument. Second and subsequent listing of the same item are referenced to the first listing with the abbreviation REF. In the case of optional

subassemblies, plug ins, etc. that are not always part of the instrument, the TOT QTY column lists the total quantity of the item in that particular assembly.

g. Entries in the REC QTY column indicate the recommended number of spare parts necessary to support one to five instruments for a period of two years. This list presumes an availability of common electronic parts at the maintenance site. For maintenance for one year or more at an isolated site, it is recommended that at least one of every part in the instrument be stocked.

h. The USE CODE column identifies certain parts which have been added, deleted or modified during the production of the instrument. Each part for which a Use Code has been assigned may be identified with a particular instrument serial number by consulting the Serial Number Effectivity List at the end of the parts list. As Use Codes are added to the list, the TOT QTY column listings are changed to reflect the most current information. Sometimes when a part is changed, the new part can and should be used as a replacement for the original part. In this event a parenthetical note is added in the DESCRIPTION column.

5-4. HOW TO OBTAIN PARTS

5-5. Standard components have been used wherever possible. Thus, most parts can be obtained locally. However, parts may be ordered directly from the manufacturer's part number. Or they may be ordered from the John Fluke Mfg. Co factory or authorized representative. In the event the part you order has been replaced by a new or improved part, the replacement will be accompanied by an explanatory note and installation instructions, if necessary.

5-6. You can insure prompt and efficient handling of your order to the John Fluke Mfg. Co. if you include the following information:

- a. Instrument model and serial number.
- b. Component description.
- c. Component reference designation.
- d. John Fluke Mfg. Co. part number.

If you must order structural parts not listed in the parts list, describe the part as completely as possible. A sketch of the part showing its location to other parts of the instrument is usually most helpful.

5-7. ABBREVIATIONS AND SYMBOLS

ABBREVIATIONS

ac	alternating current	mw	milliwatt
Al	aluminum	na	nanoampere
assy	assembly	pf	picofarad
cap	capacitor	piv	peak inverse voltage
car film	carbon film	plstc	plastic
cer	ceramic	pp	peak-to-peak
comp	composition	ppm	parts per million
conn	connector	rect	rectifier
cps	cycles per second	res	resistor
db	decibel	rms	root-mean-square
dc	direct current	sb	slow-blow
dpdt	double pole double throw	Si	silicon
dpst	double pole single throw	S/N	serial number
elect	electrolytic	sw	switch
fxd	fixed	spdt	single pole double throw
Ge	germanium	spst	single pole single throw
gmV	guaranteed minimum value	Ta	tantalum
Hz	hertz (cycles per second)	tc	temperature coefficient
K	kilohm	tstr	transistor
kc or Kc	kilocycle	ua	microampere
kHz or KHz	kilohertz (kilocycles per sec)	uf	microfarad
kv	kilovolt	uv	microvolt
kva	kilovolt-ampere	va	volt ampere
ma	milliampere	vac	alternating current volts
Mc or MC	megacycle	var	variable
MHz	megahertz (megacycles per sec)	vdc	direct current volts
meg or M	megohm	w	watt
met film	metal film	wvdc	direct current working volts
mfg	manufacturer	ww	wirewound
mv	millivolt		

PREFIX SYMBOLS

T	tera	10 ¹²
G	giga	10 ⁹
M	mega	10 ⁶
K or k	kilo	10 ³
h	hecto	10 ²
da	deka	10
d	deci	10 ⁻¹
c	centi	10 ⁻²
m	milli	10 ⁻³
u	micro	10 ⁻⁶
n	nano	10 ⁻⁹
p	pico	10 ⁻¹²
f	femto	10 ⁻¹⁵
a	anto	10 ⁻¹⁸

QUANTITY SYMBOLS

a or amp	ampere
f	farad
h	henry
hr	hour
Ω	ohm
sec	second
v or V	volt
w or W	watt

SPECIAL NOTES AND SYMBOLS

~ Approximate use code, or serial number.

Use 0000-000000

Part number indicated should be used if replacement is required.

REF DESIG	DESCRIPTION	FLUKE PART NO	MFR	MFR PART NO	TOT QTY	REC QTY	USE CODE
	FINAL ASSEMBLY-Figure 5-1 Line powered model Battery/Line powered model	887A 887AB					
A1	Chassis Assembly (see Figure 5-2)						
A2	Front Panel Assembly (see Figure 5-3)						
A100	Reference Supply Assembly (see Figure 5-4)	1702-195453 (887A-401)	89536	1702-195453	1		
A200	Null Detector Assembly (see Figure 5-5)	1702-163212 (881A-402)	89536	1702-163212	1		
A300	Kelvin-Varley Assembly (see Figure 5-6)	3158-180844 (885A-403)	89536	3158-180844	1		
A400	Attenuator Assembly (see Figure 5-7)	3158-195461 (887A-402)	89536	3158-195461	1		
A500	Converter Assembly (see Figure 5-8)	1702-166058 (883A-401)	89536	1702-166058	1		

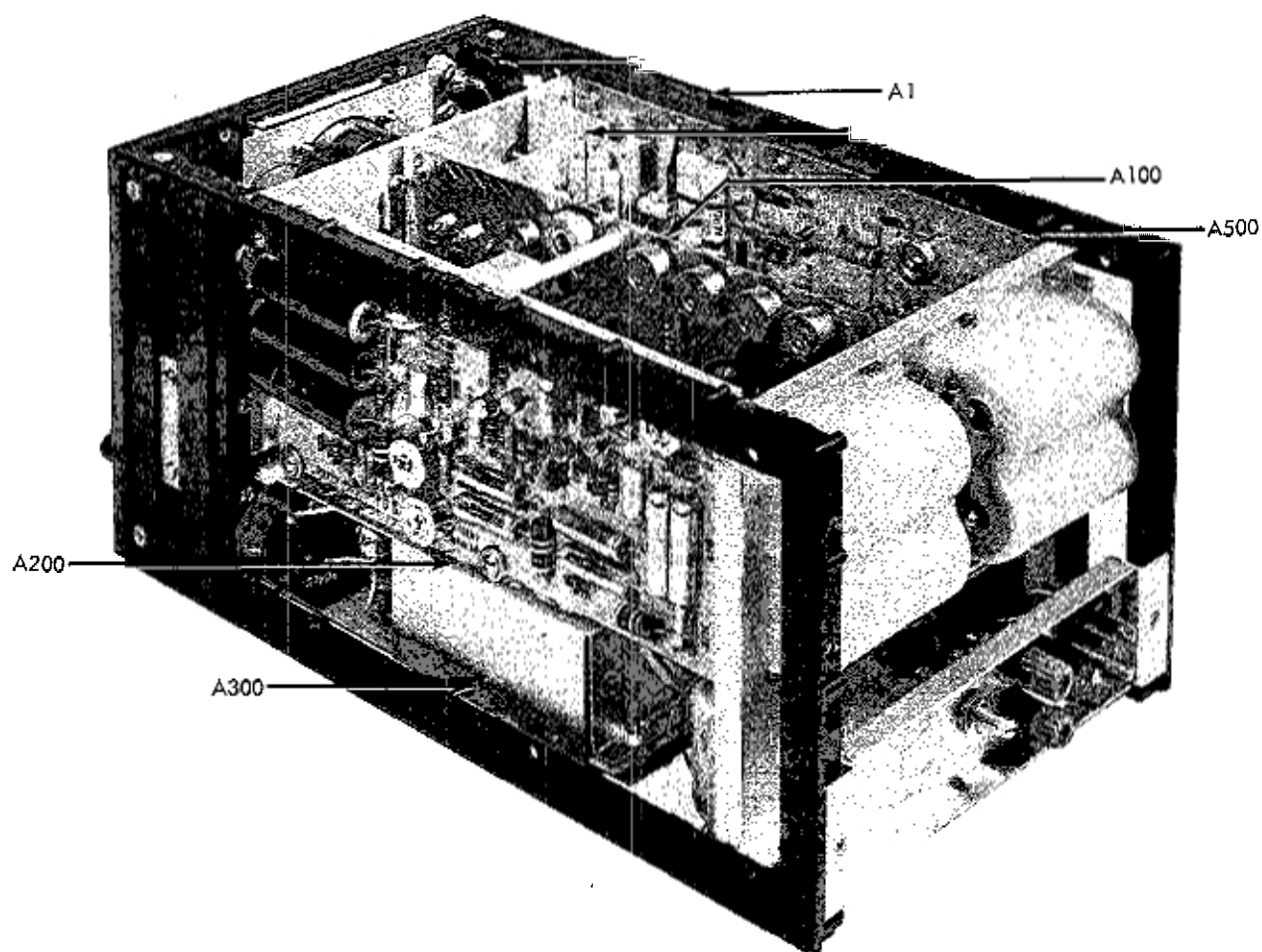

Figure 5-1. FINAL ASSEMBLY

REF DESIG	DESCRIPTION	FLUKE PART NO	MFR	MFR PART NO	TOT QTY	REC QTY	USE CODE
A1	CHASSIS ASSEMBLY-Figure 5-2						
BT1	Battery, nickel-cadmium, 9.6V	4002-160408	06860	9.6V/500BH	4		
BT2	Battery, nickel-cadmium, 1.2V	4002-160390	06860	1.2SC	4		
BT3	Battery, nickel-cadmium, 9.6V	4002-160403	06860	9.6V/500BH	REF		
C2	Cap, plstc, 0.47 uf $\pm 20\%$, 1000V	1507-161612	56289	210BIG474	1		
C3	Cap, cer, 0.1 uf $-10/+80\%$, 500V (not illustrated)	1501-105684	14752	41C92	1		
CR1, CR2	Diode, type 1N4317 (Model 887AB only)	4802-116111	05277	1N4317	6	2	
F1	Fuse, 1/16 amp, slow blowing (For 115 volt operation) (not illustrated)	5101-163030	03614	Type MDL	1	5	
	Fuse, 1/32 amp, slow blowing (For 230 volt operation) (not illustrated)	5101-163022	03614	Type MDL	1	5	
J4, J5	Binding post, red	2811-142976	58474	DF31RC	4		
P2	Plug, 3 prong	2109-160275	01730	M-1550-GS	1		
R2, R3	Res, met flm, 4.5M $\pm 1\%$, 1W	4705-159418	14298	Type CM-1	2		
R4	Res, met flm, 900K $\pm 1\%$, 1W	4705-159509	72982	Type MF8C-T0	1		
R5	Res, met flm, 90K $\pm 1\%$, 1/2W	4705-159509	72982	Type MF7C-T0	1		
R6	Res, met flm, 9K $\pm 1\%$, 1/2W	4705-159434	72982	Type MF7C-T0	1		
R7	Res, met flm, 1K $\pm 1\%$, 1/2W	4705-151324	72982	Type MF7C-T0	2		
R8	Res, var, comp, 10K $\pm 20\%$, 1/2W	4701-162800	12697	Series 37	1		
R9	Res, comp, 62K $\pm 5\%$, 1/2W (Model 887AB only)	4704-108522	01121	EB6235	2		
R10	Res, comp, 10M $\pm 10\%$, 1/2W	4704-108142	01121	EB1061	2		
R11	Res, comp, 130 Ω $\pm 5\%$, 1W (Model 887AB only)	4704-163055	01121	GB1315	3		
R12	Res, comp, 10 Ω $\pm 5\%$, 1W (Model 887AB only)	4704-166298	01121	GB1005	1		
R13	Res, comp, 130 Ω $\pm 5\%$, 1W (Model 887AB only)	4704-163055	01121	GB1315	REF		
S1	Switch, rotary, 2 pol, 2 pos, 1 section (Model 887A only) (not illustrated)	5105-162693	89536	5105-162693	1		
	Switch, rotary, 8 pol, 5 pos, 4 section (Model 887AB only)	5105-163360	89536	5105-163360	1		
S2	Switch, rotary, 8 pol, 4 pos, 5 section	5105-162719	89536	5105-162719	1		

REF DESIG	DESCRIPTION	FLUKE PART NO	MFR	MFR PART NO	TOT QTY	REC QTY	USE CODE
S3	Switch, rotary, 7 pol, 5 pos, 5 section	5105-162669	89536	5105-162669	1		
S4	Switch, rotary, 8 pol, 3 pos, 4 section (not illustrated)	5105-162701	89536	5105-162701	1		
T1	Transformer, power	5602-162818	89536	5602-162818	1		
1	Cover, bottom (not illustrated)	3156-162198	89536	3156-162198	1		
2	Cover, side, front	3158-162164	89536	3158-162164	2		
3	Cover, side, rear	3158-162172	89536	3158-162172	2		
4	Cover, top	3156-162180	89536	3156-162180	1		
5	Fuse holder	2102-160846	75915	34-2004	1		
6	Handle	2404-101857	12136	919-415-173	1		
7	Rubber foot (not illustrated)	2819-103309	83478	9102-W	4		
8	Tilt stand	3153-163386	89536	3153-163386	1		
9	Line Cord	6005-161638	89536	6005-161638	1		

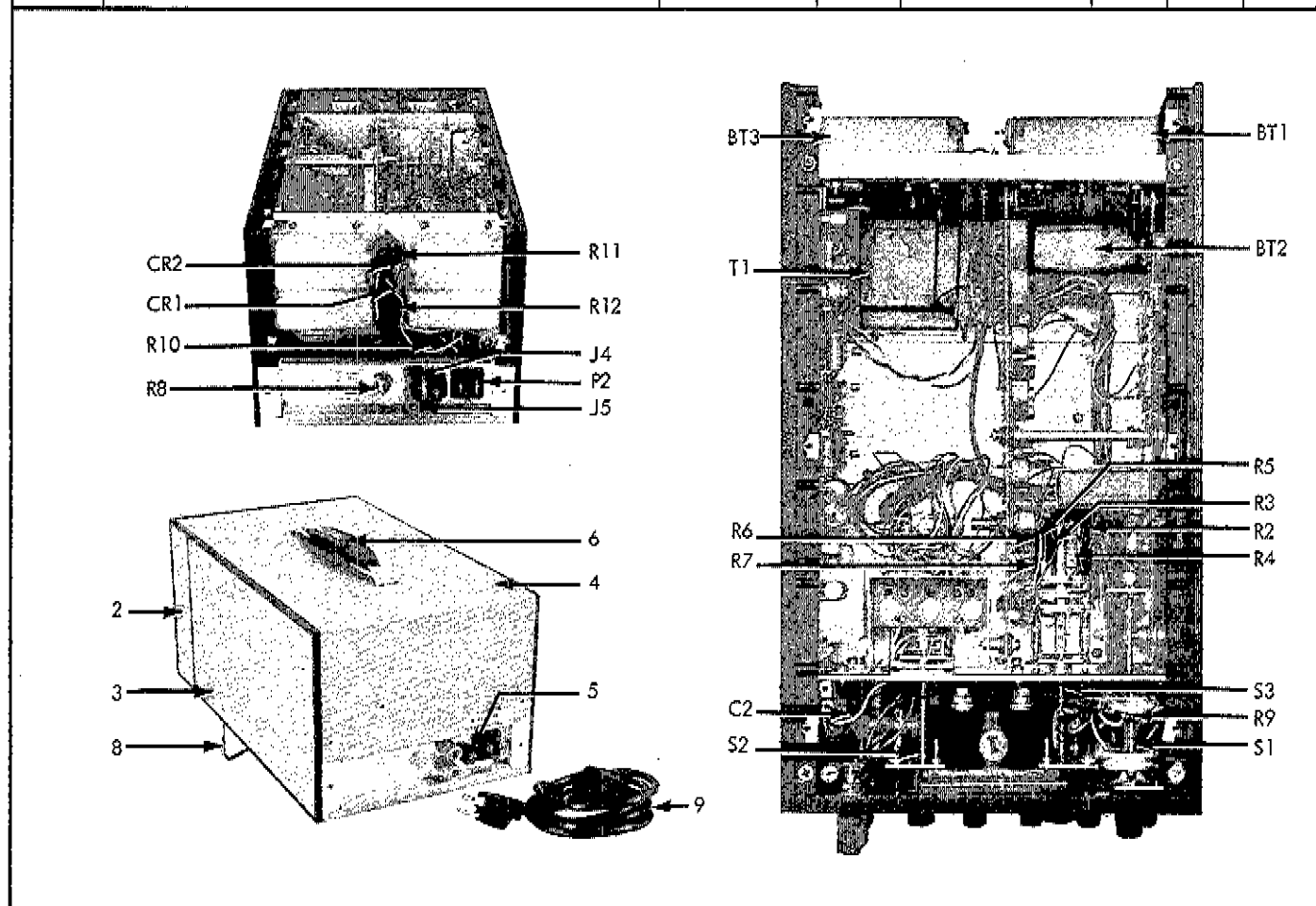

Figure 5-2. CHASSIS ASSEMBLY

REF DESIG	DESCRIPTION	FLUKE PART NO	MFR	MFR PART NO	TOT QTY	REC QTY	USE CODE
A2	FRONT PANEL ASSEMBLY-Figure 5-3						
C1	Cap, plstc, 0.01 uf $\pm 20\%$, 1000V	1507-159996	84411	663UW103010W	1		
C4*	Cap, elect, 640 uf $-10/+50\%$, 6.4V	1502-178608	73445	C437ARC640	1		
J1, J2	Binding post, red	2811-142976	58474	DF31RC	REF		
J3	Binding post, black	2811-142984	58474	DF31BC	1		
M1	Meter, 100-0-100 ua 887A (not illustrated) 887AB	2901-210236 2901-201244	89536 89536	2901-201236 2901-201244	1 1		
R15*	Res, comp, $270\Omega \pm 10\%$, 1/2W	4704-108241	01121	EB2711	1		
10	Knob, NULL and RANGE	2405-158956	89536	2405-158956	2		
11	Knob, POWER	3156-162196	89536	3156-162196	1		
12	Knob, voltage	2405-158949	89536	2405-158949	6		
13	Null-Range shutter	3156-162263	89536	3156-162263	1		
14	Nylon bushing	2502-160499	96881	AL2-FF	9		
15	Panel, front 887A (not illustrated) 887AB	1406-195396 1406-195511	89536 89536	1406-195396 1406-195511	1 1		
16	Shorting link	2811-101220	24655	Type 938L	1		

* C4 and R15 provide meter damping. On some instruments, a different meter is used not requiring external damping. The above listing is the preferred replacement.

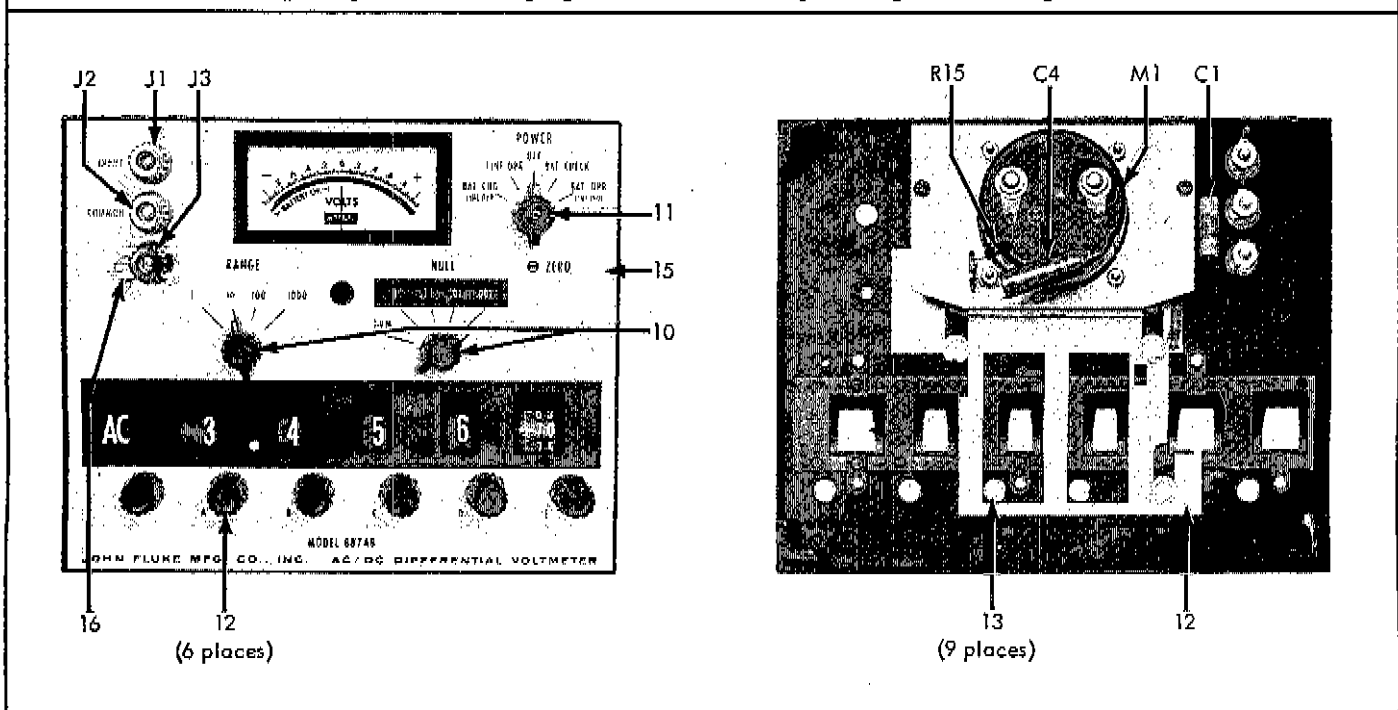











Figure 5-3. FRONT PANEL ASSEMBLY

REF DESIG	DESCRIPTION	FLUKE PART NO	MFR	MFR PART NO	TOT QTY	REC QTY	USE CODE
A3	REFERENCE SUPPLY ASSEMBLY-Figure 5-4	1702-195453 (887A-401)	89536	1702-195453	1		
	Input-Divider Set	1702-180901	89536	1702-180901	1		
R121	Res, WW, 49.488K						
R123	Res, WW, 6.111K						
	Input-Resistor Set	4710-195487	89536	4710-195487	1		
R100, R101, R102	Res, WW, 3.3M						
R104	Res, WW, 100.05K						
	Zener-Resistor Set	4807-176123	89536	4807-176123	1		
CR103, CR104	Diode, zener						
R109	Res, WW, 8K						
R110	Res, WW, 16.5 - 20.4K						
R117	Res, WW, 675-830Ω						
R119	Res, WW, 6-10K						
C101	Cap, elect, 500 uf -10/+50%, 15V	1502-160101	93790	BR 500-15	1	1	
C102	Cap, elect, 150 uf -10/+50%, 50V	1502-160119	93790	BR 150-50	1	1	
C103	Cap, mylar, 0.022Ω ±10%, 75V	1507-159400	56289	192P2239R8	1		
C104	Cap, mylar, 0.22Ω ±10%, 75V	1507-159392	56289	192P2249R8	2		
C105, C106	Cap, Ta elect, 2.2 uf ±10%, 20V	1508-160226	05397	K2R2C20K	4		
C107	Cap, mylar, 0.22Ω ±10%, 75V	1507-159392	56289	192P2249R8	REF		
CR101, CR102	Diode, type 1N4317	4802-116111	05227	1N4317	REF		
CR105	Diode, zener, type 1N961A	4803-113324	07910	1N961A	1	1	
Q101	Tstr, Continental Devices, type CDQ10656	4805-193870	07910	CDQ10656	6	2	
Q102	Tstr, type 2N1303	4805-148619	01295	2N1303	1	1	
Q103	Tstr, matched pair	4805-182246	89536	4805-182246	1	1	
Q104	Tstr, Motorola, type SM4144	4805-190389	04713	SM4144	3	1	
Q105	Tstr, type 2N404	4805-163188	01295	2N404	1	1	
Q106, Q107	Tstr, type 2N1307	4805-148643	01295	2N1307	2	1	

REF DESIG	DESCRIPTION	FLUKE PART NO	MFR	MFR PART NO	TOT QTY	REC QTY	USE CODE
Q108, Q109	Tstr, type 2N1304	4805-117127	01295	2N1304	1	1	
R103	Res, var, WW, 10K \pm 10%, 2W	4702-163147	71450	Type 118	1		
R105	Res, comp, 33 Ω \pm 5%, 1W	4704-163063	01121	GB3305	1		
R106	Res, comp, 330 Ω \pm 5%, 1W	4704-163394	01121	GB3315	1		
R107	Res, comp, 1.8M \pm 10%, 1/2W	4704-108720	01121	EB1851	1		
R111	Res, var, WW, 500 Ω \pm 20%, 1 1/4W	4702-112433	71450	Type 110	1		
R112	Res, met film, 23.2K \pm 1%, 1/2W	4705-159459	75042	Type CEC-TO	2		
R113	Res, met film, 8.06K \pm 1%, 1/2W	4705-159467	75042	Type CEC-TO	1		
R114	Res, met film, 10K \pm 1%, 1/2W	4705-151274	75042	Type CEC-TO	2		
R115	Res, met film, 23.2K \pm 1%, 1/2W	4705-159459	75042	Type CEC-TO	REF		
R116	Res, comp, 5.6K \pm 10%, 1/2W	4704-108324	01121	EB5621	1		
R118	Res, comp, 10 Ω \pm 10%, 1/2W	4704-108092	01121	EB1001	1		
R120	Res, var, WW, 10 Ω \pm 10%, 1 1/4W	4702-112672	71450	Type 110	1		
R122	Res, var, WW, 25 Ω \pm 10%, 1 1/4W	4702-161703	71450	Type 110	1		
R124	Res, var, WW, 1K \pm 20%, 1 1/4W	4702-111575	71450	Type 110	2		
R125	Res, comp, 2.7K \pm 5%, 1/2W	4704-109074	01121	EB2725	3		
R126	Res, var, WW, 1K \pm 20%, 1 1/4W	4702-111575	71450	Type 110	REF		
R127	Res, comp, 2.7K \pm 5%, 1/2W	4704-109074	01121	EB2725	REF		
R128, R129	Res, comp, 4.7K \pm 10%, 1/2W	4704-108381	01121	EB4721	2		
R130, R131	Res, comp, 1K \pm 10%, 1/2W	4704-108503	01121	EB1021	2		
R132	Res, comp, 82 Ω \pm 5%, 1/2W	4704-108746	01121	EB8205	1		
100	Polyethelene grommet	2807-171876	89536	2807-171876	13		
101	Polyethelene grommet	2807-171884	89536	2807-171884	1		



This resistor is factory selected for each instrument. When ordering, include all information on old resistor and/or information on the Reference Supply Board decal.



Factory selected. If replacement is required, replace with a new Zener-Resistor Set.

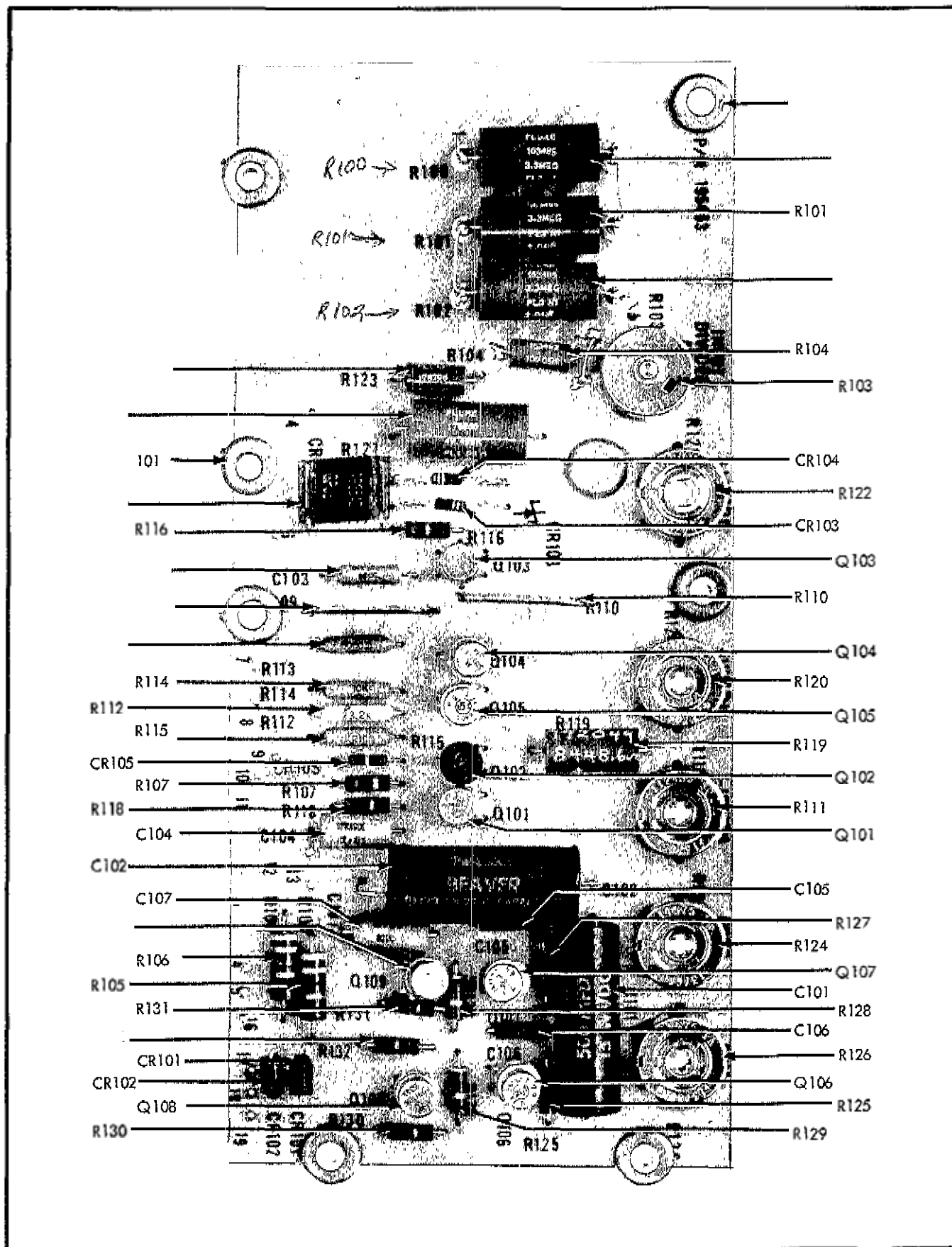

Figure 5-4. REFERENCE SUPPLY ASSEMBLY

REF DESIG	DESCRIPTION	FLUKE PART NO	MFR	MFR PART NO	TOT QTY	REC QTY	USE CODE
A200	NULL DETECTOR ASSEMBLY-Figure 5-5	1702-163212 (881A-402)	89536	1702-163212	1		
C201 Thru C203	Cap, plstc, 0.22 ±10%, 75V (specially treated)	1507-162766	89536	1507-162766	3		
C204	Cap, plstc, 0.047 uf ±20%, 100V	1507-106096	84411	663UW47301	1		
C205	Cap, Al elect, 100 uf -10/+75%, 25V	1502-106518	56289	30D107G025DH4	3	1	
C206	Cap, Al elect, 40 uf -10/+75%, 6V	1502-105205	56289	30D406G006BB4	1	1	
C207	Cap, Al elect, 5 uf -10/+75%, 25V	1502-152009	56289	30D505G025BA4	2	1	
C208, C209	Cap, Al elect, 100 uf -10/+75%, 25V	1502-106518	56289	30D107G025DH4	REF		
C210	Cap, cer, 0.01 uf -20/+80%, 500V	1501-105668	56289	29C9B5	3		
C211	Cap, Al elect, 200 uf -10/+75%, 6V	1502-105189	56289	30D207G006DF4	1	1	
C212	Cap, plstc, 0.0047 uf ±20%, 200V	1507-106054	84411	663UW47202	1		
C213	Cap, Al elect, 20 uf -10/+75%, 50V	1502-106229	56289	30D206G050DC4	3	1	
C214	Cap, cer, 0.01 uf -20/+80%, 500V	1501-105668	56289	29C9B5	REF		
C215	Cap, Al elect, 500 uf -10/+75%, 3V	1502-106328	56289	30D507G003DH4	2		
C216	Cap, cer, 0.01 uf -20/+80%, 500V	1501-105668	56289	29C9B5	REF		
C217	Cap, Al-elect, 5 uf -10/+75%, 25V	1502-152009	56289	30D505G025BA4	REF		
C218	Cap, Al elect, 20 uf -10/+75%, 50V	1502-106229	56289	30D206G050DC4	REF		
C219	Cap, Al elect, 500 uf -10/+75%, 3V	1502-106328	56289	30D507G003DH4	REF		
C220	Cap, Ta elect, 2.2 uf ±10%, 20V	1508-160226	05397	K2R2C20K	1		
CR201 CR202	Diode, Continental Devices, type CD13161	4802-113308	07910	CD13161	2	1	
DS201	Lamp, neon, type NE2E (specially treated)	3902-162776	89536	3902-162776	1	1	
G201	Chopper, mechanical, SPDT (specially treated)	5901-162784	89536	5901-162784	1	1	
Q201	Tstr, field effect, P-channel	4805-159210	17856	U-112	1	1	
Q202 thru Q205	Tstr, Continental Devices, type CDQ10656	4805-193370	07910	CDQ10656	REF		
Q206	Tstr, type 2N1372	4805-116129	01295	2N1372			
R201	Res, comp, 220K ±10%, 2W	4704-110197	01121	HB2241	1		

REF DESIG	DESCRIPTION	FLUKE PART NO	MFR	MFR PART NO	TOT QTY	REC QTY	USE CODE
R202, R203	Res, comp, 220K \pm 10%, 1/2W	4704-108217	01121	EB2241	2		
R204	Res, comp, 1M \pm 10%, 1/2W	4704-108134	01121	EB1051	2		
R205	Res, comp, 22K \pm 10%, 1/2W	4704-108209	01121	EB2231	4		
R206	Res, comp, 1K \pm 10%, 1/2W	4704-108563	01121	EB1021	4		
R207	Res, met flm, 8.06K \pm 1%, 1/2W	4705-159467	75042	Type CEC-TO	1		
R208	Res, var, WW, 5K \pm 5%, 2W	4702-111609	71450	Type 115	1		
R209	Res, comp, 10K \pm 10%, 1/2W	4704-108118	01121	EB1031	2		
R210	Res, comp, 1.8K \pm 10%, 1/2W	4704-108860	01121	EB1821	2		
R211	Res, comp, 47K \pm 10%, 1/2W	4704-108480	01121	EB4731	2		
R212	Res, comp, 1K \pm 10%, 1/2W	4704-108563	01121	EB1021	REF		
R213	Res, comp, 6.8K \pm 10%, 1/2W	4704-108399	01121	EB6821	1		
R214	Res, comp, 180 Ω \pm 10%, 1/2W	4704-108571	01121	EB1811	1		
R215	Res, comp, 15K \pm 10%, 1/2W	4704-108530	01121	EB1531	2		
R216	Res, comp, 47K \pm 10%, 1/2W	4704-108480	01121	EB4731	REF		
R217	Res, comp, 9.1K \pm 5%, 1/2W	4704-160028	01121	EB9125	1		
R218	Res, comp, 27K \pm 10%, 1/2W	4704-108878	01121	EB2731	2		
R219	Res, comp, 1.8K \pm 10%, 1/2W	4704-108860	01121	EB1821	REF		
R220	Res, comp, 39 Ω \pm 10%, 1/2W	4704-160036	01121	EB3901	1		
R221	Res, comp, 7.5K \pm 5%, 1/2W	4704-108910	01121	EB7525	1		
R222	Res, comp, 22K \pm 10%, 1/2W	4704-108209	01121	EB2231	REF		
R223	Res, comp, 10K \pm 10%, 1/2W	4704-108118	01121	EB1031	REF		
R224	Res, comp, 1K \pm 10%, 1/2W	4704-108563	01121	EB1021	REF		
R225	Res, comp, 3.9K \pm 10%, 1/2W	4704-161406	01121	EB3921	1		
R226 R227	Res, comp, 47K \pm 10%, 2W	4704-110015	01121	HB4731	REF		
R228	Res, comp, 1.5K \pm 10%, 1/2W	4704-108159	01121	EB1521	1		
R229	Res, met flm, 402 Ω \pm 1%, 1/2W	4705-150839	75042	Type CEC-TO	1		
R230	Res, var, WW, 100 Ω \pm 20%, 1-1/4W	4702-112797	71450	Type 110	1		
R231	Res, var, WW, 10K \pm 5%, 2W	4702-112862	71450	Type 110	2		
R232	Res, met flm, 90.9K \pm 1%, 1/2W	4705-162974	75042	Type CEC-TO	1		

REF DESIG	DESCRIPTION	FLUKE PART NO	MFR	MFR PART NO	TOT QTY	REC QTY	USE CODE
R233	Res, met flm, 909K ±1%, 1/2W	4705-159483	75042	Type CEC-TO	1		
R234	Res, met flm, 1K ±1%, 1/2W	4705-151324	75042	Type CEC-TO	1		
R235	Res, met flm, 8.45K ±1%, 1/2W	4705-159475	75042	Type CEC-TO	1		
R236	Res, met flm, 200Ω ±1%, 1/2W	4705-151480	75042	Type CEC-TO	1		
R237	Res, comp, 6.8M ±10%, 1/2W	4704-108662	01121	EB6851	1		
R238	Res, comp, 56K ±10%, 1/2W	4704-108472	01121	EB5631	2		
R239	Res, var, comp, 100K ±30%, 3/10W (not illustrated)	4704-163402	71450	Type 70	1		
R240	Res, comp, 180K ±10%, 1/2W	4704-108431	01121	EB1841	1		
200	Polyethelene grommet	2807-171876	39536	2807-171876	REF		

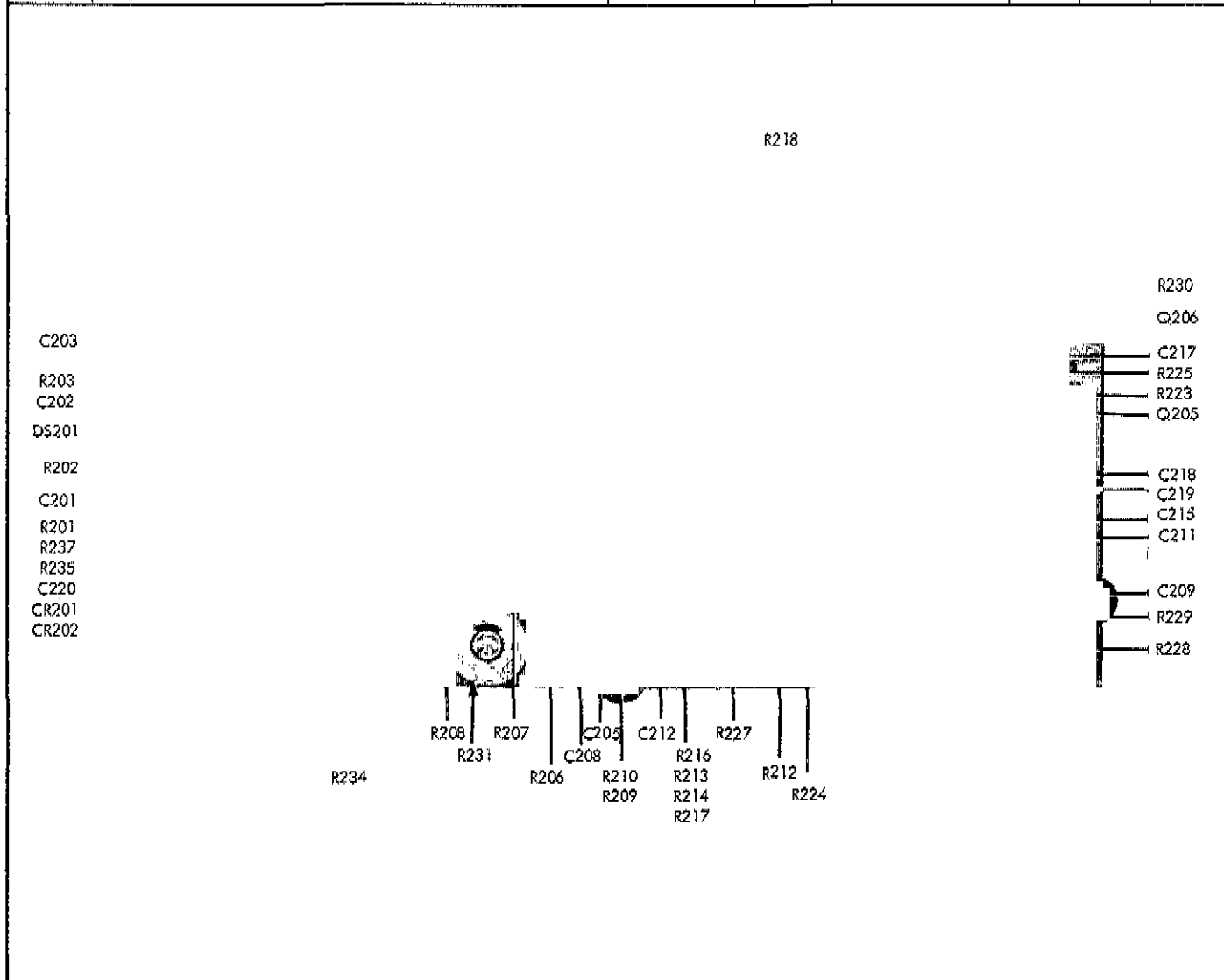









Figure 5-5. NULL DETECTOR ASSEMBLY

REF DESIG	DESCRIPTION	FLUKE PART NO	MFR	MFR PART NO	TOT QTY	REC QTY	USE CODE
A300	KELVIN-VARLEY ASSEMBLY-Figure 5-6	4710-180844 (885A-403)	89536	4710-180844	1		
C301	Cap, plstc, 1 uf $\pm 20\%$, 200V	1507-106450	82376	RLR-21M	1		
R301	Res, var, WW, 25K $\pm 10\%$, 5W	4702-182634	71450	Type UPM-AW	2		
R302	Res, WW, 500K $\pm 1\%$, 1W	4707-177063	80031	Type WM4SF	2		
R303	Res, comp, WW, 5.05K $\pm 0.02\%$, 3/4W						
R304	Res, var, WW, 25K $\pm 10\%$, 5W	4702-182634	92376	Type UPM-AW	REF		
R305	Res, WW, 500K $\pm 1\%$, 1W	4704-177063	80031	Type WM4SF	REF		
R306	Res, WW, 5.05K $\pm 0.02\%$, 3/4W						
Odd No From R307 to R325	Res, var, WW, 2 Ω $\pm 10\%$, 2W	4702-182410	71450	Type 115 Special	12		
Even No. From R308 to R326	Res, WW, 5K $+0.01/-0.03\%$, 3/4W						
R327 thru R337	Res, WW, 1K $+0.02/-0.018\%$, 1/4W						
R338	Res, var, WW, 2 Ω $\pm 10\%$, 2W	4702-182410	71450	Type 115 Special	REF		
R339	Res, WW, 2.499K $\pm 0.02\%$, 1/2W						
R340 thru R350	Res, WW, 1K $\pm 0.04\%$, 1/2W						
R351	Res, var, WW, 2 Ω $\pm 10\%$, 2W	4702-182410	71450	Type 115 Special	REF		
R352	Res, WW, 2.499K $\pm 0.02\%$, 1/2W						
R353 thru R363	Res, WW, 1K $\pm 0.04\%$, 1/2W						
R364	Res, var, WW, 1K $\pm 20\%$, 1-1/4W	4702-111575	71450	Type 110	REF		
R365	Res, met film, 9.35K $\pm 1\%$. 1/2W (not illustrated)	4705-159442	75042	Type CEC-TO	1		
R366	Res, var, WW, 2.5K $\pm 0.05\%$	4711-163154	89536	4711-163154	1		
S5	Switch, rotary, 2 pol, 11 pos, 2 section	5105-162644	89536	5105-162644	1		

REF DESIG	DESCRIPTION	FLUKE PART NO	MFR	MFR PART NO	TOT QTY	REC QTY	USE CODE
S6	Switch, rotary, 2 pol, 10 pos, 2 section	5105-162636	89536	5105-162636	1		
S7	Switch, rotary, 2 pol, 2 pos, 2 section	5105-162651	89536	5105-162651	1		
S8	Switch, rotary, 2 pol, 10 pos, 2 section	5105-162636	89536	5105-162636			



These resistors are factory matched. When ordering, include all information stamped on old resistor.

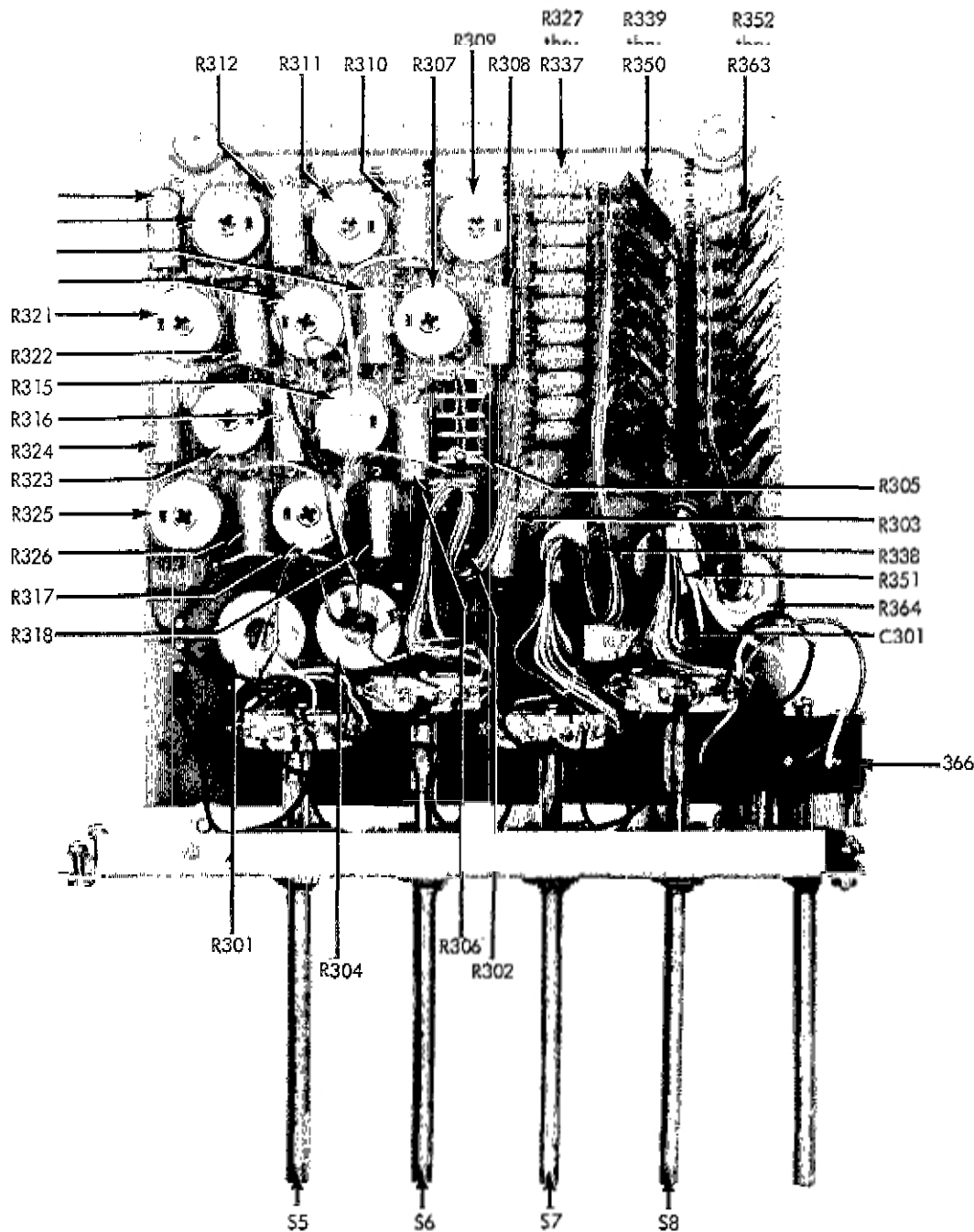

Figure 5-6. KELVIN-VARLEY ASSEMBLY

REF DESIG	DESCRIPTION	FLUKE PART NO	MFR	MFR PART NO	TOT QTY	REC QTY	USE CODE
A400	ATTENUATOR ASSEMBLY-Figure 5-7	3158-195461 (887A-402)	89536	3158-195461	1		
	Resistor Set	4705-159814	89536	4705-159814	1		
R401	Res, met flm, 900K	1					
R402	Res, met flm, 109K	1					
	Resistor Set	4705-159830	89536	4705-159830	1		
R404	Res, met flm, 990K	1					
R405	Res, met flm, 9.88K	1					
	Resistor Set	4705-159806	89536	4705-159806	1		
R407, R408	Res, met flm, 500K	1					
R409	Res, met flm, 976Ω	1					
C401	Cap, var alumina, 1.0 ±010 pf, 400V	1509-188698	91273	JMC2903	4		
C402	Cap, cer, 15 pf ±10%, 500V	1501-159947	00656	Type C1-1	2		
C403	Cap, var alumina, 1.0 to 10 pf, 400V	1509-188698	91273	JMC2903	REF		
C404	Cap, mica, 150 pf ±5%, 500V	1504-148478	88419	CD15F151J	1		
C405	Cap, var alumina, 1.0 to 10 pf, 400V	1509-188698	91273	JMC2903	REF		
C406	Cap, cer, 5.1 pf ±5%, 1100V	1501-187682	00656	C1-2	2		
C407	Cap, mica, 3,000 pf ±5%, 500V	1504-161786	88419	CD19F302J	1		
R403	Res, var, met flm, 5K ±20%, 3/4W	4701-159905	80740	Type 78P	1		
R406	Res, var, met flm, 500Ω ±20%, 3/4W	4701-159897	80740	Type 78P	1		
R410	Res, var, met flm, 100Ω ±20%, 3/4W	4701-159889	80740	Type 78B	1		
R411	Res, comp, 82K ±5%, 1/4W	4704-188458	01121	CB8235	1		

1 Factory selected. If replacement is required, replace with new resistor set.

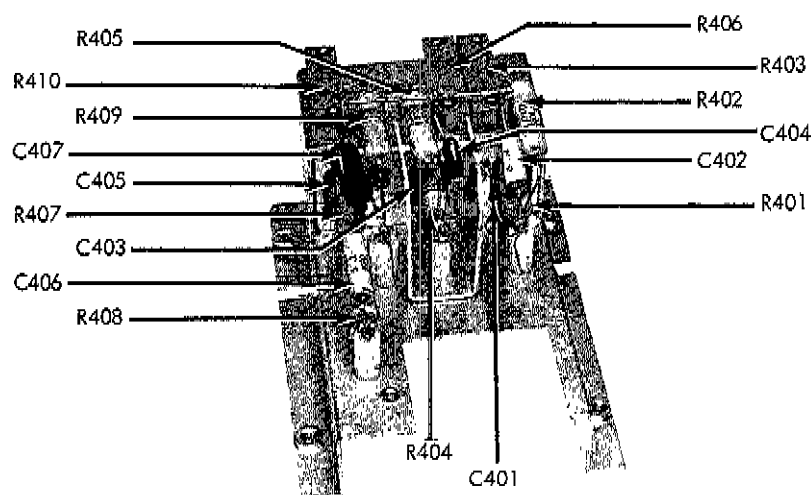
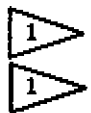



Figure 5-7. ATTENUATOR ASSEMBLY

REF DESIG	DESCRIPTION	FLUKE PART NO	MFR	MFR PART NO	TOT QTY	REC QTY	USE CODE
A500	CONVERTER BOARD ASSEMBLY Figure 5-8	1702-166058 (883A-401)	89536	1702-166058	1		
	Resistor Set	4705-159822	89536	4705-159822	1		
R501	Res, WW, 1M \pm 1%, 1W						
R502	Res, WW, 246K \pm 1/2%, 1W						
C501	Cap, cer, 5.0 pf \pm 5%, 1100V	1501-187682	00656	Type C1-2	REF		
C502	Cap, var, alumina, 1.0 to 10 pf, 400V	1509-188698	91273	JMC2903	REF		
C503	Cap, cer, 15 pf \pm 10%, 500V	1501-159947	00656	Type C1-1	REF		
C504	Cap, plstc, 5 uf \pm 20%, 20V	1507-160952	00656	V-146-ZR	1		
C505	Cap, Al. elect, 30 uf +75/-10%, 15V	1502-106492	56289	30D306G015CB4	1	1	
C506	Cap, Al. elect, 250 uf +75/-10%, 12V	1502-160002	56289	30D275G012DH4	2	1	
C507	Cap, mica, 33 pf \pm 5%, 500V	1504-160317	88419	CD15E330J	1		
C508	Cap, Ta. elect, 68 uf \pm 20%, 6V	1508-160242	05397	K68P6	1	1	
C509	Cap, mica, 22 pf \pm 5%, 500V	1504-148551	88419	CD15E220J	1		
C510	Cap, Al. elect, 250 uf +75/-10%, 12V	1502-160002	56289	30D275G015CB4	REF		
C511	Cap, Ta. elect, 10 uf \pm 10%, 20V	1508-160259	05397	K10C20K	1	1	
C512	Cap, plstc, 0.001 uf \pm 10%, 200V	1507-159582	56289	192P10292	1		
C513	Cap, Ta. elect, 2.2 uf \pm 10%, 20V	1508-160226	05397	K2R2C20K	REF		
C514	Cap, Ta. elect, 150 uf \pm 10%, 6V	1508-160234	05397	K150C6K	1	1	
C516	Cap, plstc, 0.00047 uf \pm 10%, 200V	1507-159574	56289	192P47192	1		
C517	Cap, Ta. elect, 150 uf +20/-15%, 1.5V	1508-160945	56289	109D157C2015TC	1	1	
C518 thru C519	Cap, plstc, 2 uf \pm 20%, 10V	1507-160960	00656	V-146-ZR	1		
C520	Cap, Al. elect, 50 uf +75/-10%, 50V	1502-105122	56289	30D506G050DH4	1	1	
C521	Cap, Ta. elect, 2.2 uf \pm 10%, 20V	1508-160226	05397	K2R2C20K	REF		
C522	Cap, Al. elect, 30 uf +75/-10%, 15V	1502-106492	56289	30D306G015CB4	1		
C523	Cap, Al. elect, 20 uf +75/-10%, 50V	1502-106229	56289	30D206G050DC4	REF		
CR501	Diode, Transitron type SG5337	4802-161810	03877	SG5337	3	1	
CR502	Diode, Zener, .6.8V, Continental Devices type CD36554	4803-187195	07910	CD36554	2	1	
CR503, CR504	Diode, Transitron type SG5337	4802-161810	03877	SG5337	REF		

REF DESIG	DESCRIPTION	FLUKE PART NO	MFR	MFR PART NO	TOT QTY	REC QTY	USE CODE
CR505	Diode, type 1N4317	4802-116111	05277	1N4317	REF		
CR506	Diode, Zener, 6.8V, type 1N754	4803-166199	07910	1N754	1		
CR507	Diode, type 1N4317	4802-116111	05277	1N4317	REF		
Q501	Tstr, field effect, N-channel	4805-166223	15818	U-1249	1	1	
Q502 thru Q506	Tstr, Continental Devices type CDQ23102	4805-159855	07910	CDQ23102	4	1	
Q507	Tstr, Motorola, type SM4144	4805-190389	04713	SM4144	REF		
Q508	Tstr, Continental Devices type CDQ10656	4805-193870	07910	CDQ10656	REF		
Q509	Tstr, Motorola, type SM4144	4805-190389	04713	SM4144	REF		
R504	Res, WW, 125 Ω \pm 1%, 1/4W	4707-159764	15909	Type R1136	1		
R505	Res, comp, 1K \pm 10%, 1/2W	4704-108563	01121	EB1021	REF		
R506	Res, comp, 1M \pm 10%, 1/2W	4704-108134	01121	EB1051	REF		
R507	Res, comp, 22K \pm 10%, 1/2W	4704-108209	01121	EB2231	REF		
R508	Res, var, WW, 10K \pm 20%, 1-1/4W	4702-112862	71450	Type 110	REF		
R509	Res, comp, 10K \pm 5%, 1/2W	4704-109165	01121	EB1035	4		
R510	Res, comp, 56K \pm 10%, 1/2W	4704-108472	01121	EB5631	REF		
R511	Res, comp, 16K \pm 5%, 1/2W	4704-159632	01121	EB1635	1		
R512	Res, comp, 10K \pm 5%, 1/2W	4704-109165	01121	EB1035	REF		
R513	Res, comp, 270 Ω \pm 5%, 1/2W	4704-159616	01121	EB2715	1		
R514	Res, comp, 2.7K \pm 5%, 1/2W	4704-109074	01121	EB2725	REF		
R515	Res, comp, 8.2 Ω \pm 5%, 1/2W	4704-159590	01121	EB82G5	1		
R516	Res, comp, 68K \pm 5%, 1/2W	4704-159624	01121	EB6835	1		
R517	Res, comp, 27K \pm 10%, 1/2W	4704-108878	01121	EB2731	REF		
R518	Res, comp, 3.3K \pm 10%, 1/2W	4704-108373	01121	EB3321	1		
R519	Res, comp, 15K \pm 10%, 1/2W	4704-108530	01121	EB1531	REF		
R520	Res, comp, 470 Ω \pm 5%, 1/2W	4704-108787	01121	EB4715	2		
R521	Res, comp, 62K \pm 5%, 1/2W	4704-108522	01121	EB6235	REF		
R522	Res, var, 100K \pm 30%, 1/2W	4701-160010	71450	Type UPE70	1		
R523	Res, comp, 300 Ω \pm 5%, 1/2W	4704-108829	01121	EB3015	1		
R524	Res, comp, 47 Ω \pm 5%, 1/2W	4704-159608	01121	EB4705	1		

REF DESIG	DESCRIPTION	FLUKE PART NO	MFR	MFR PART NO	TOT QTY	REC QTY	USE CODE
R525	Res, comp, 470Ω ±5%, 1/2W	4704-108787	01121	EB4715	REF		
R526	Res, comp, 330Ω ±5%, 1/2W	4704-108936	01121	EB3315	2		
R527	Res, comp, 10K ±5%, 1/2W	4704-109165	01121	EB1041	1		
R528	Res, comp, 100K ±10%, 1/2W	4704-108126	01121	EB1041	1		
R529	Res, comp, 2.7K ±10%, 1/2W	4704-108837	01121	EB2721	1		
R530, R531	Res, WW, 547Ω ±0.1%, 1/4W	4707-159772	15909	Type R1136	2	1	
R532, R533	Res, met film, 51.1K ±1%, 1/2W	4705-159665	75042	Type CEC-TO	1		
R534	Res, comp, 330Ω ±5%, 1/2W	4704-108936	01121	EB3315	REF		
R535	Res, comp, 2.2K ±5%, 1/2W	4704-108506	01121	EB2225	1		
R536	Res, comp, 1.5M ±10%, 1/2W	4704-108175	01121	EB1551	1		
R537	Res, comp, 22K ±10%, 1/2W	4704-108209	01121	EB2231	REF		
R538	Res, met film, 10K ±1%, 1/2W	4705-151247	75042	Type CEC-TO	REF		
R539	Res, var, WW, 3K ±20%, 2W	4702-153429	71450	Type 115	1		
R540	Res, met film, 5.11K ±1%, 1/2W	4705-159657	75042	Type CEC-TO	REF		
R541	Res, comp, 1.1Ω ±5%, 1/2W	4705-163717	01121	EB11G5	1		
R542	Res, comp, 10K ±5%, 1/2W	4704-109165	01121	EB1035	REF		
R543	Res, comp, 24K ±5%, 1/2W	4704-108654	01121	EB2435	1		
R544	Res, comp, 22M ±10%, 1/2W	4704-108233	01121	EB2261	1		
R545	Res, comp, 130Ω ±5%, 1W	4704-163055	01121	GB1315	1		



These resistors are factory matched. When ordering include all information stamped on old resistor.

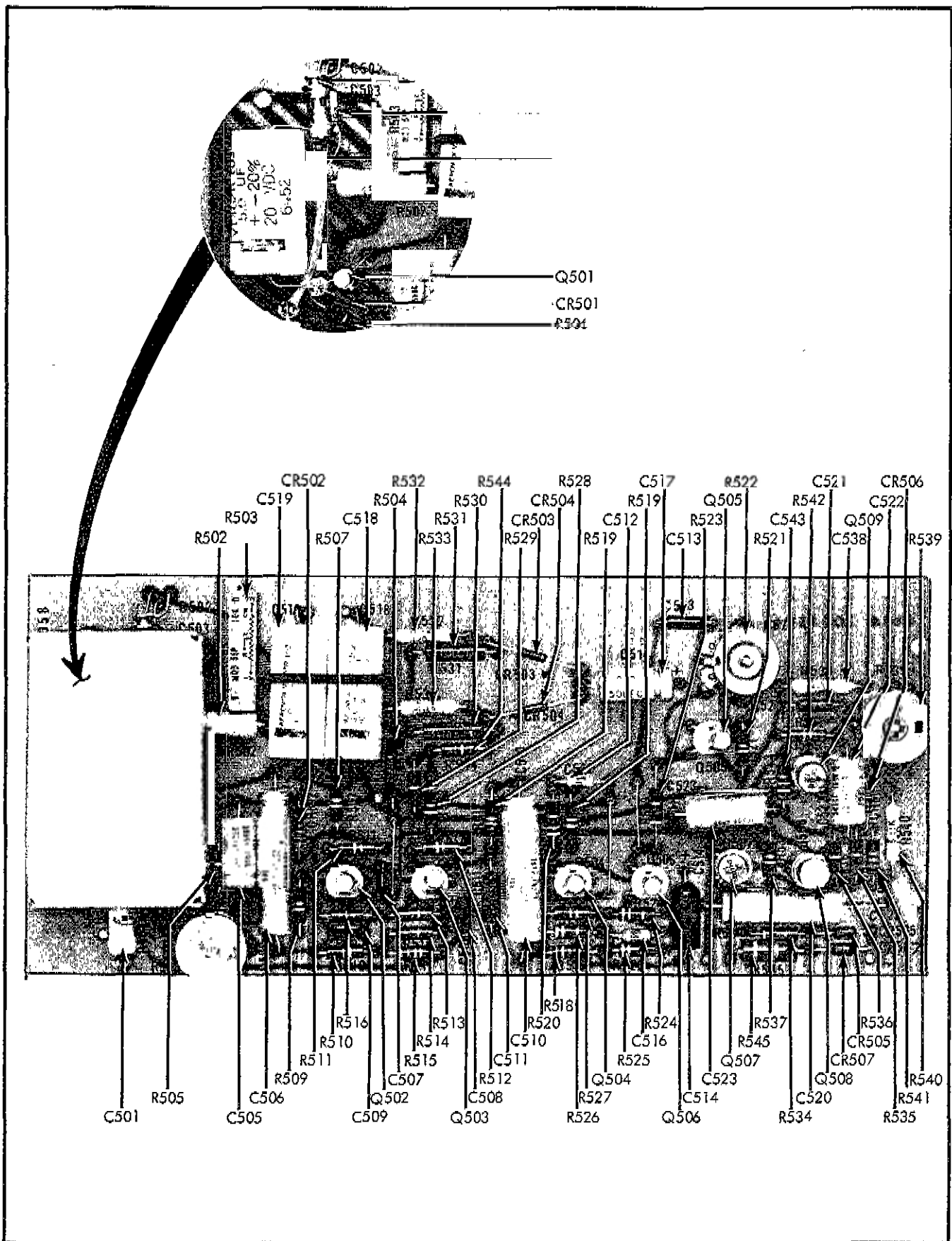

Figure 5-8. CONVERTER BOARD ASSEMBLY

5-8. SERIAL NUMBER EFFECTIVITY

5-9. A Use Code column is provided to identify certain parts that have been added, deleted, or modified during production of the 887A & 887AB. Each part for which a use code has been assigned may be identified with a particular instrument serial number by consulting the list below. All parts with no code are used on all instruments with serial numbers above 123. New codes will be added as required by instrument changes.

USE CODE	EFFECTIVITY
-------------	-------------

No Code	Model 887A and 887AB serial number 123 and on
------------	---

SECTION VI

ACCESSORIES

6-1. PRECISION VOLTAGE DIVIDERS

6-2. The FLUKE 80A, 80D, and 80E Voltage Dividers provide the FLUKE 800 Series Differential Voltmeters with the ability to make high accuracy measurements up to 30,000 volts DC. All models contain a zero center panel meter which allows the polarity and approximate magnitude of the unknown high voltage to be easily observed. At maximum input, all units draw but 1 ma of current from the unknown. The extreme accuracy and excellent long term stability of these dividers are obtained by using properly aged precision wirewound resistors which have a very low temperature coefficient. To further ensure high accuracy and long term stability at very high voltages, the 80D dividers have all resistance components immersed in oil within a hermetically sealed container. As an additional feature, all 80D and 80E models are provided with a 1 volt tap which allows measurements of high voltages with a laboratory potentiometer. Specifications for the standard models are shown on next page. Other intermediate models are available upon special request.

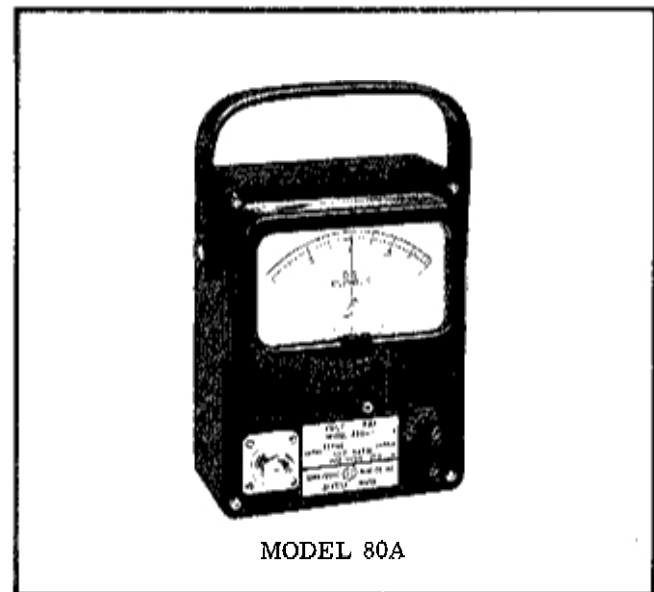

MODEL 80A

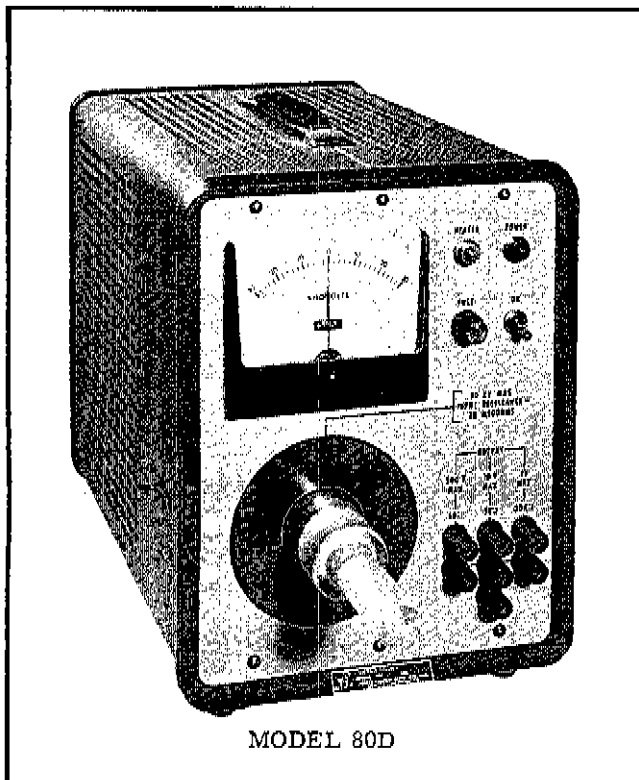

MODEL 80D

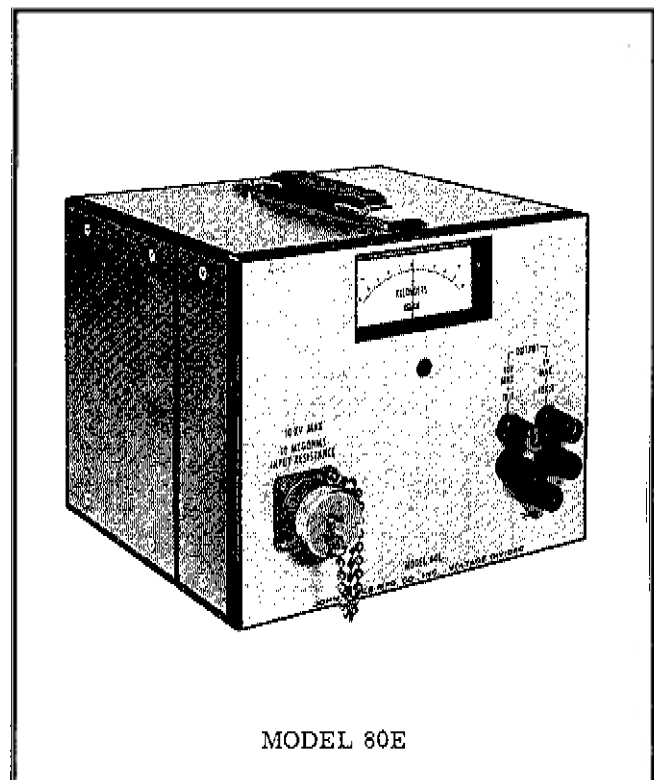

MODEL 80E

Model No.	Maximum Input Voltage	Total Resistance	Current Drawn At Max. Input	Division Ratio			Division Ratio Accuracy	Stability of Division Accuracy Per Year
				500V Out	10V Out	1V Out		
80A-1	1 KV	1 M	1 ma	2:1	—	—	±0.015%	—
80A-2	2 KV	2 M	1 ma	4:1	—	—	±0.015%	—
80E-5	5 KV	5 M	1 ma	—	500:1	5,000:1	±0.01%	±0.01%
80E-10	10 KV	10 M	1 ma	—	1000:1	10,000:1	±0.01%	±0.01%
80D-30	30 KV	30 M	1 ma	60:1	3000:1	30,000:1	±0.01%	±0.01%

MODELS	SIZE	INPUT CONNECTOR	OUTPUT CONNECTOR
80A	6-3/4" high 5-1/4" wide 2-1/4" deep	UG-560U with mating connector supplied	Insulated binding posts on 3/4" centers
80E	7" high 8-1/2" wide 8" deep	MS3102A-18-165 with mating connector supplied	Insulated binding posts on 3/4" centers for both outputs
80D	13" high 9-3/4" wide 16" deep	Special 5" ceramic standoff with mating 6" guard supplied	Insulated binding post on 3/4" centers for both outputs

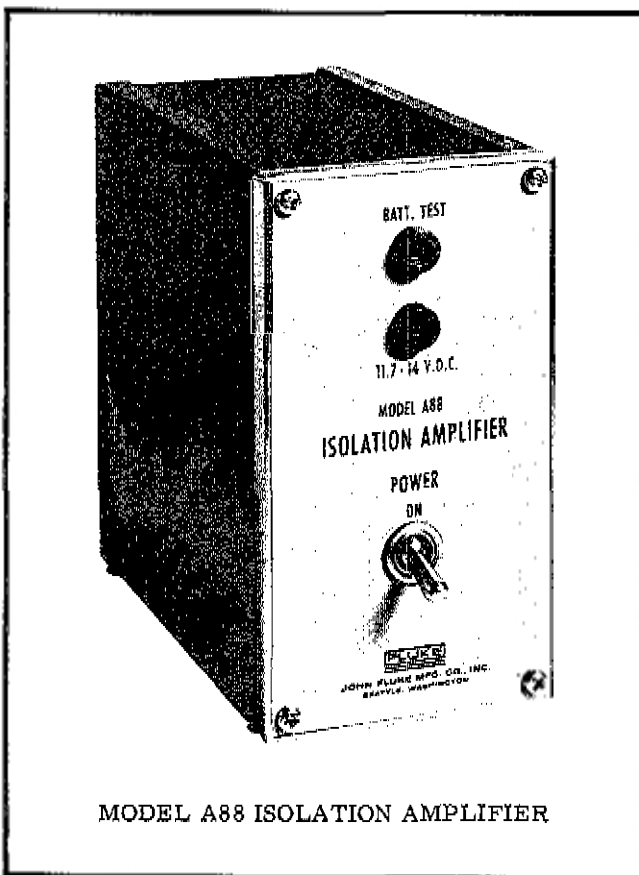

6-3. ISOLATION AMPLIFIER

6-4. The FLUKE Model A88 all solid-state isolation amplifier is designed to provide isolation between the output of a differential voltmeter and the input of a recorder. Thus, the A88 will allow the use of a wide range of strip chart recorders for recording the voltmeter reading without regard to the input isolation characteristics of the recorder. The A88 is also excellent for making accurate dc microvolt and nanoampere measurements in the presence of common mode voltages up to 1100 vdc and 3 vac, 50 to 500 cycles.

GAIN: 1 volt output per microampere input.

GAIN ACCURACY: ±2%.

INPUT CURRENT RANGE: 0 to 2 microamperes.

INPUT VOLTAGE RANGE: 0 to 2 millivolts nominal.

INPUT RESISTANCE: 950 ohms (±5%).

OUTPUT VOLTAGE RANGE: 0 to 2 volts open circuit.

OUTPUT RESISTANCE: 1000 ohms (±5%).

INPUT ISOLATION FROM CHASSES: Greater than 5×10^{11} ohms at 25°C (77°F), 60% RH and 1×10^{10} ohms at 50°C (122°F), 80% RH.

FLUKE 887A
DIFFERENTIAL VOLTMETER
SHT. 1 OF 6

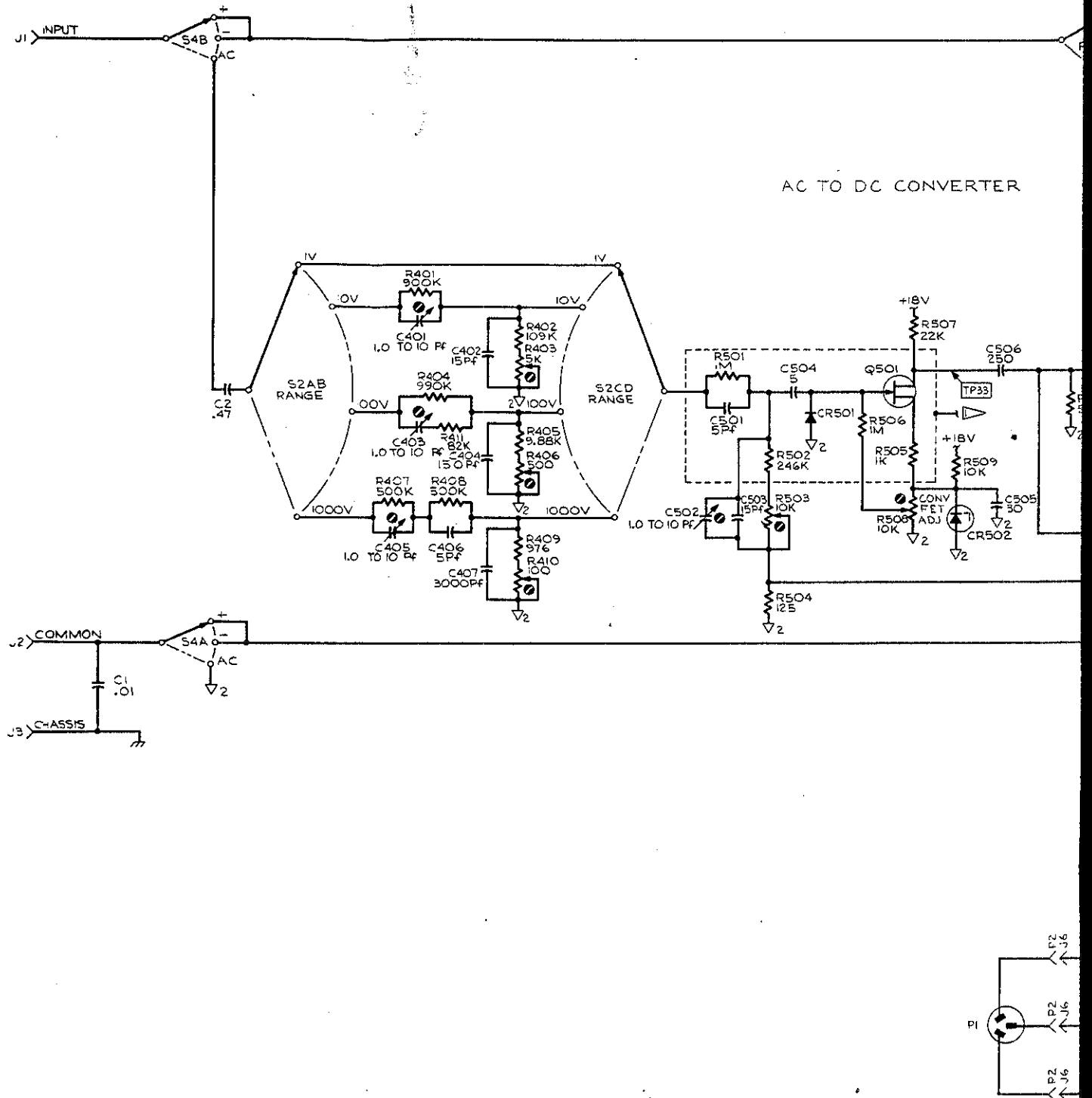

DIFFERENTIAL VOLTMETER

SHT. 3 OF 6

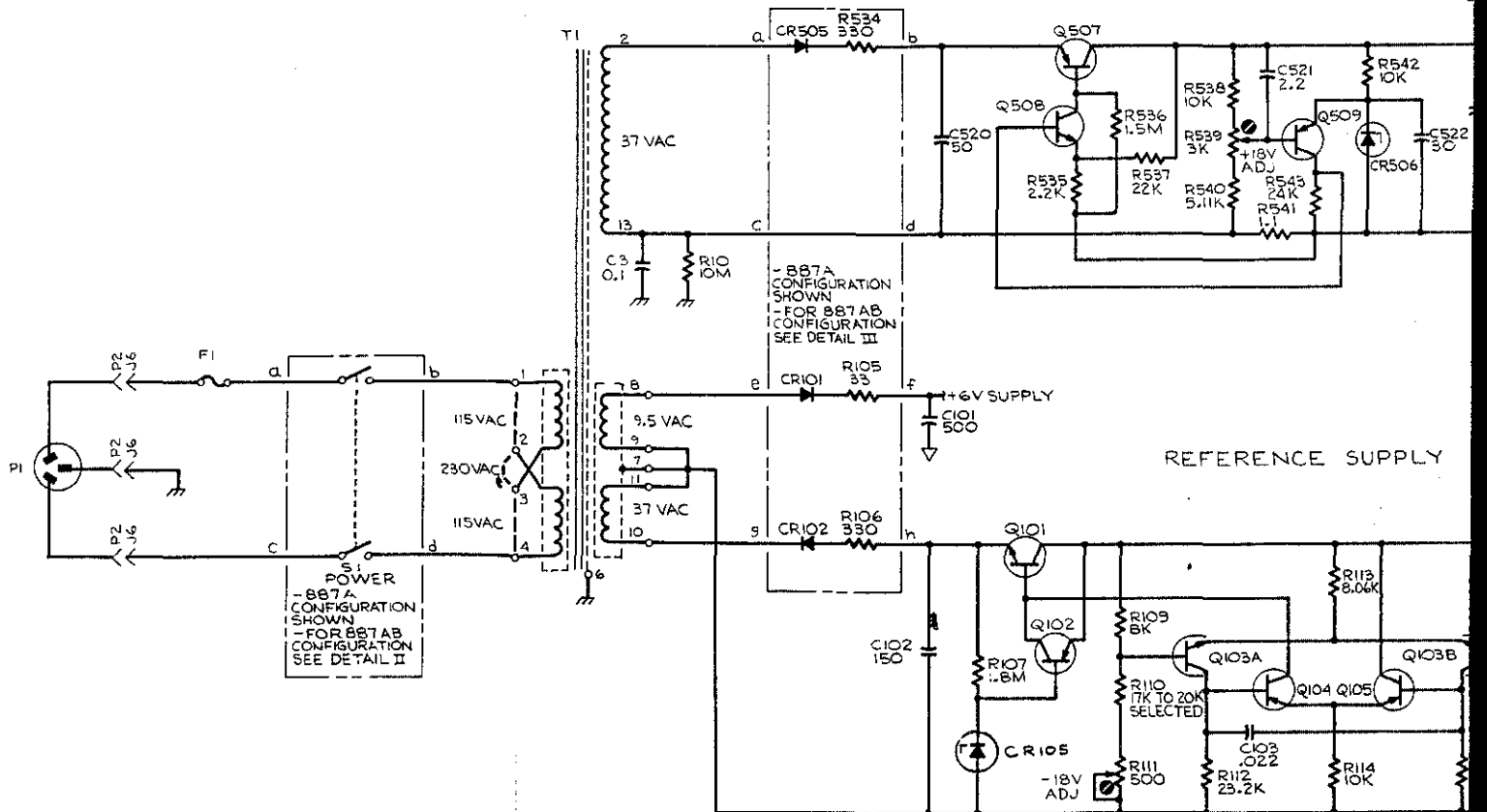
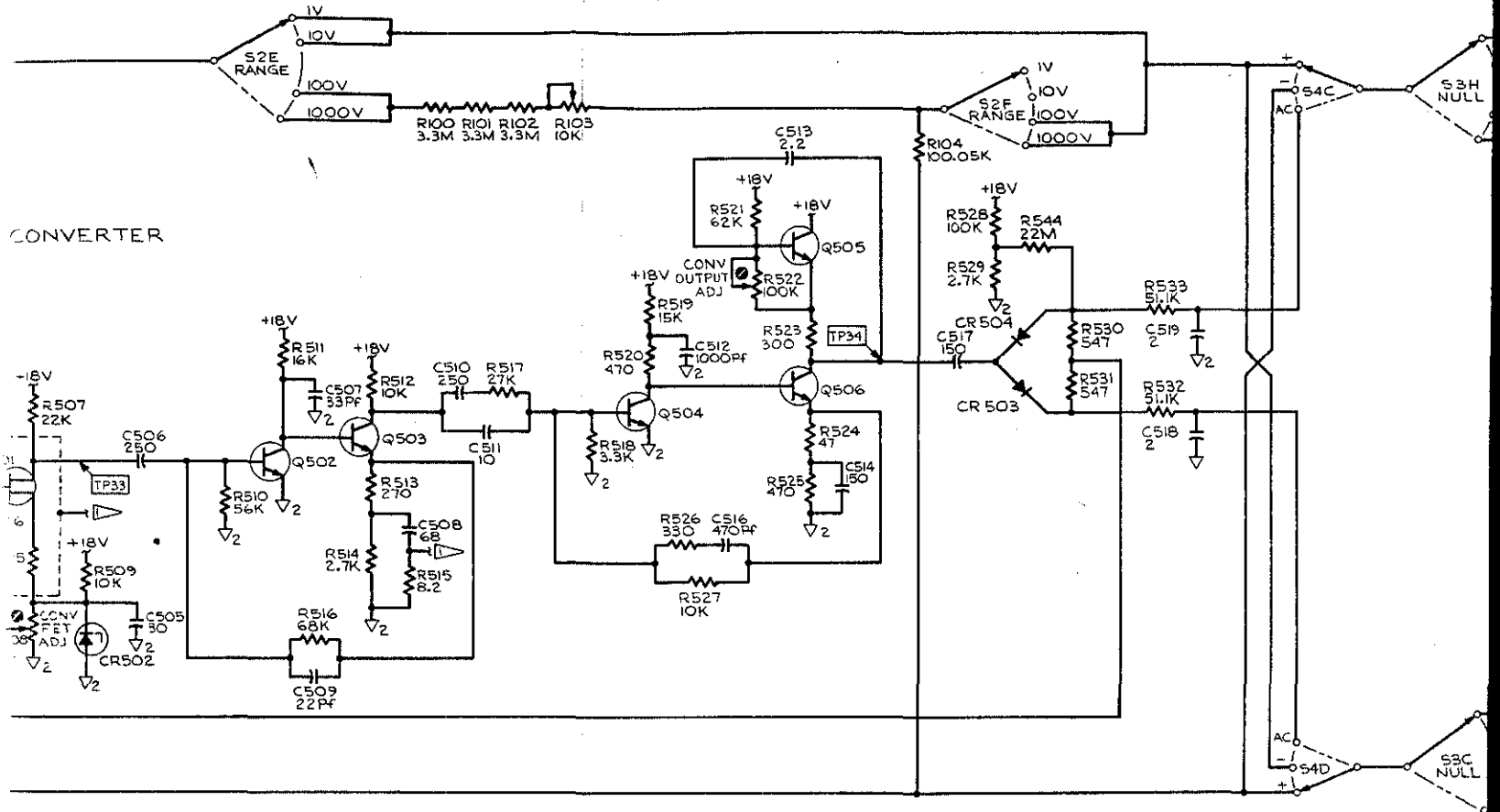

DIFFERENTIAL VOLT METER

SHT. 3 OF 6

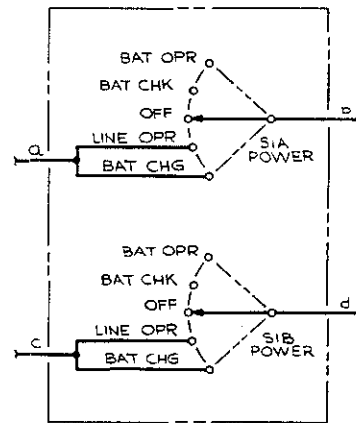
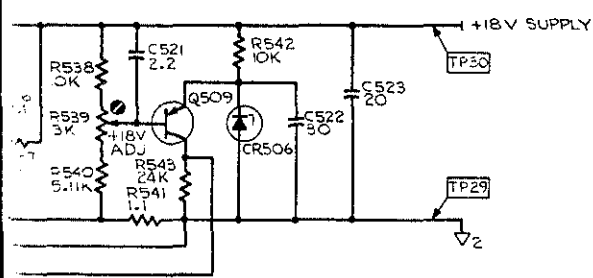
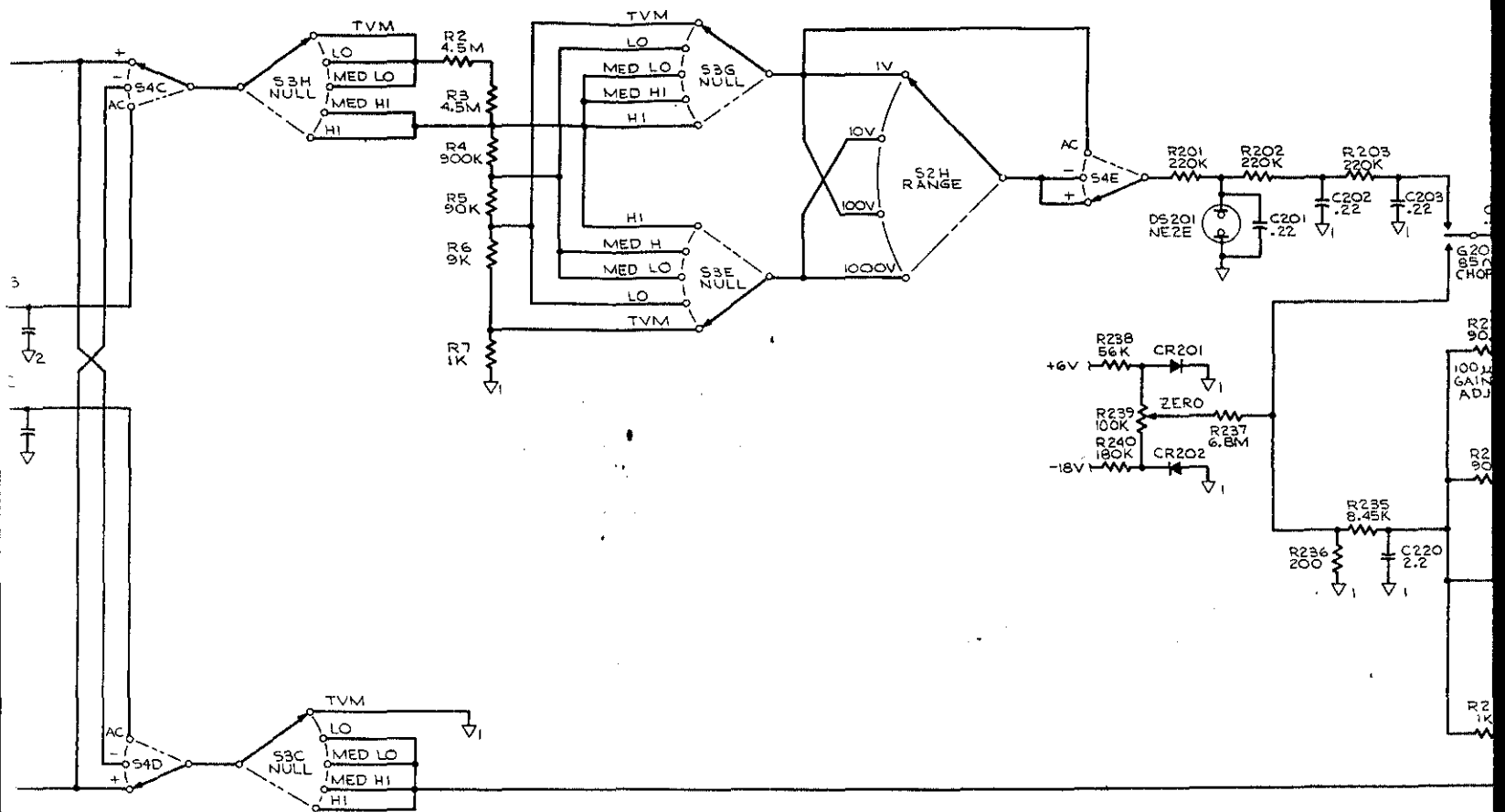

REFERENCE SUPPLY

DETAIL II

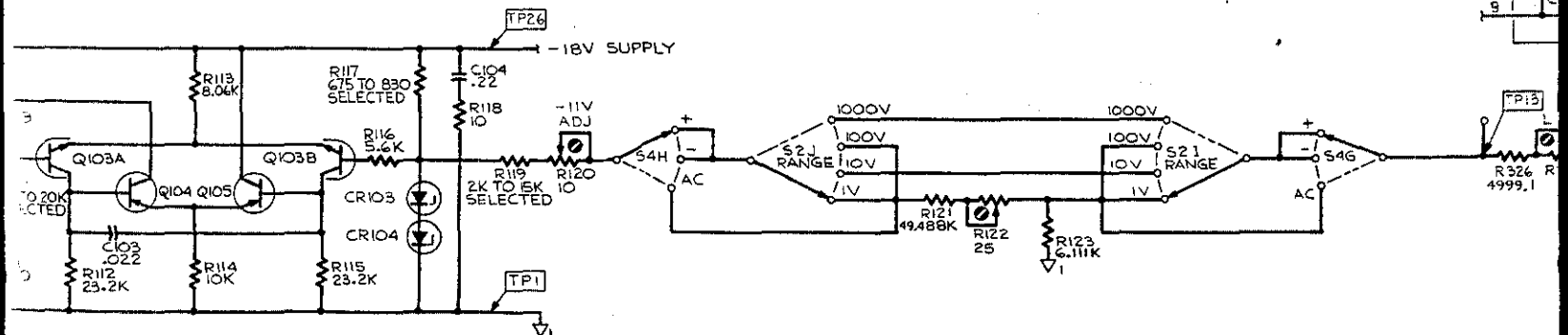

DIFFERENTIAL VOLTMETER

SHT. 4 OF 6

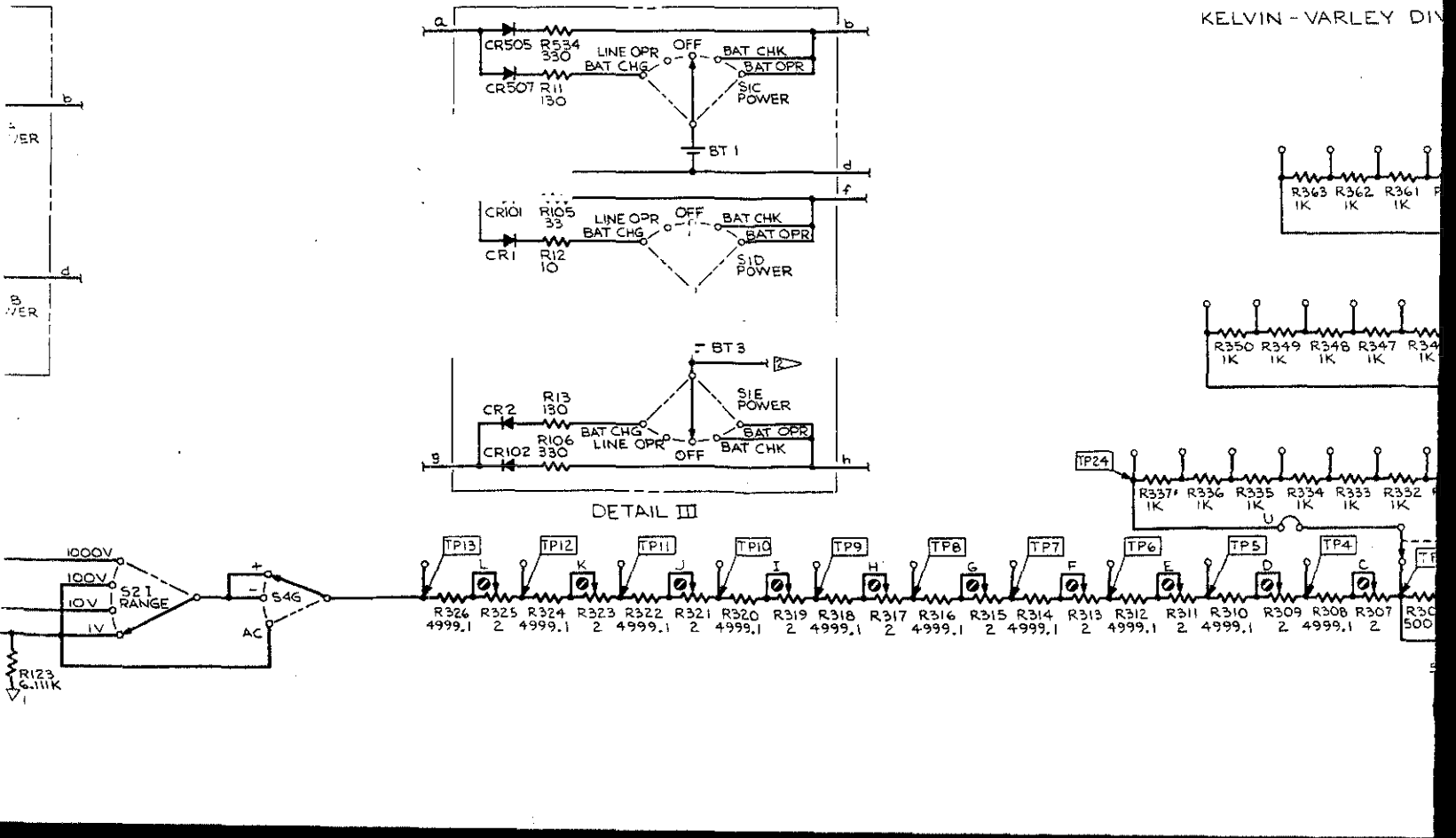
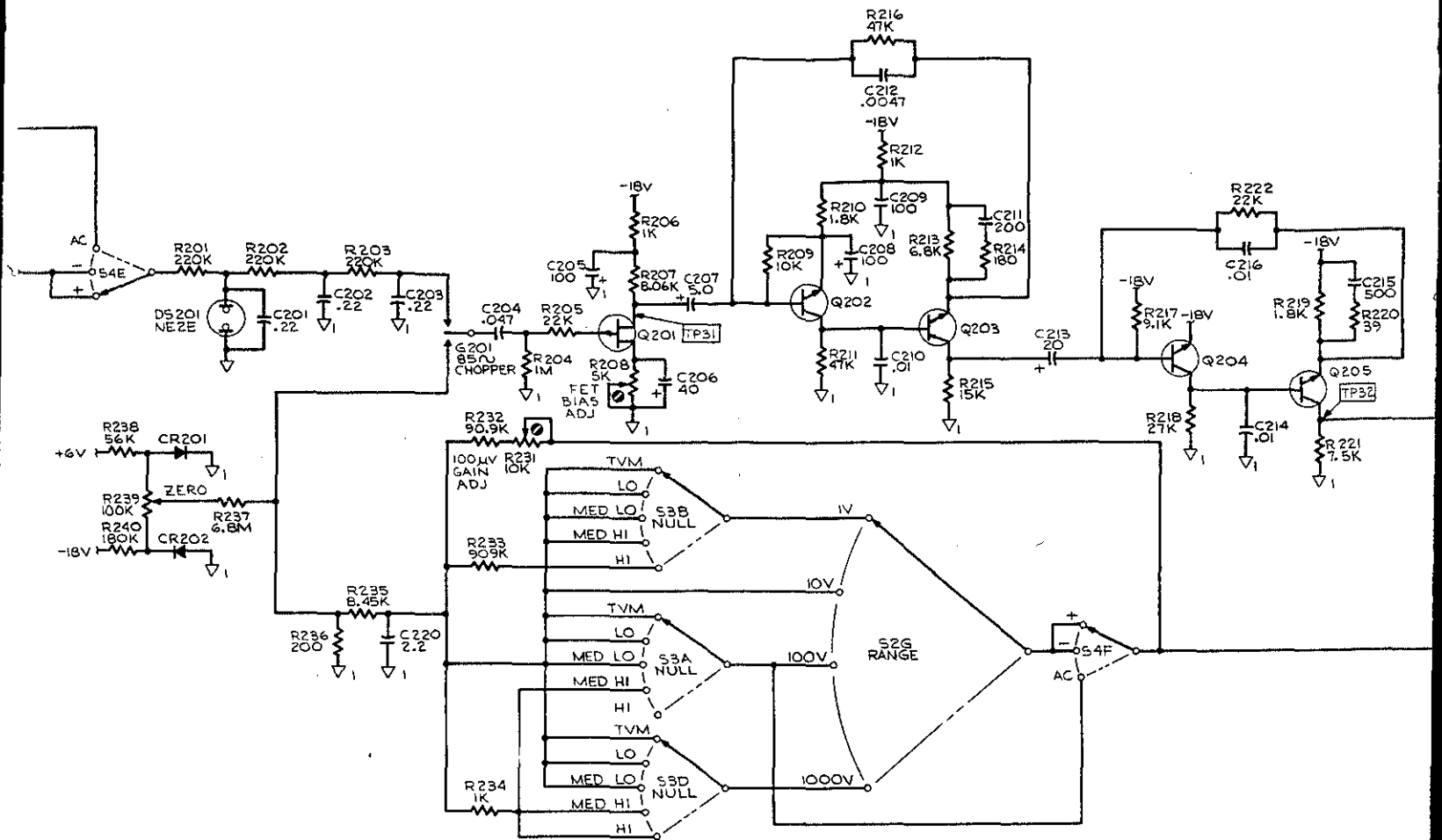

DIFFERENTIAL VOLTMETER

SHT. 5 OF 6

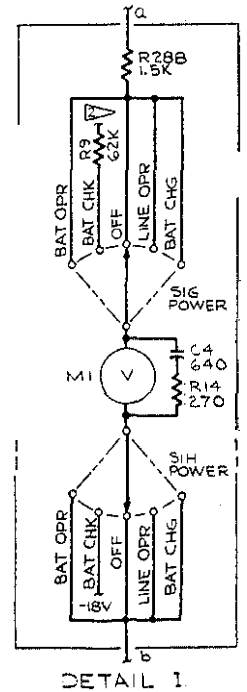
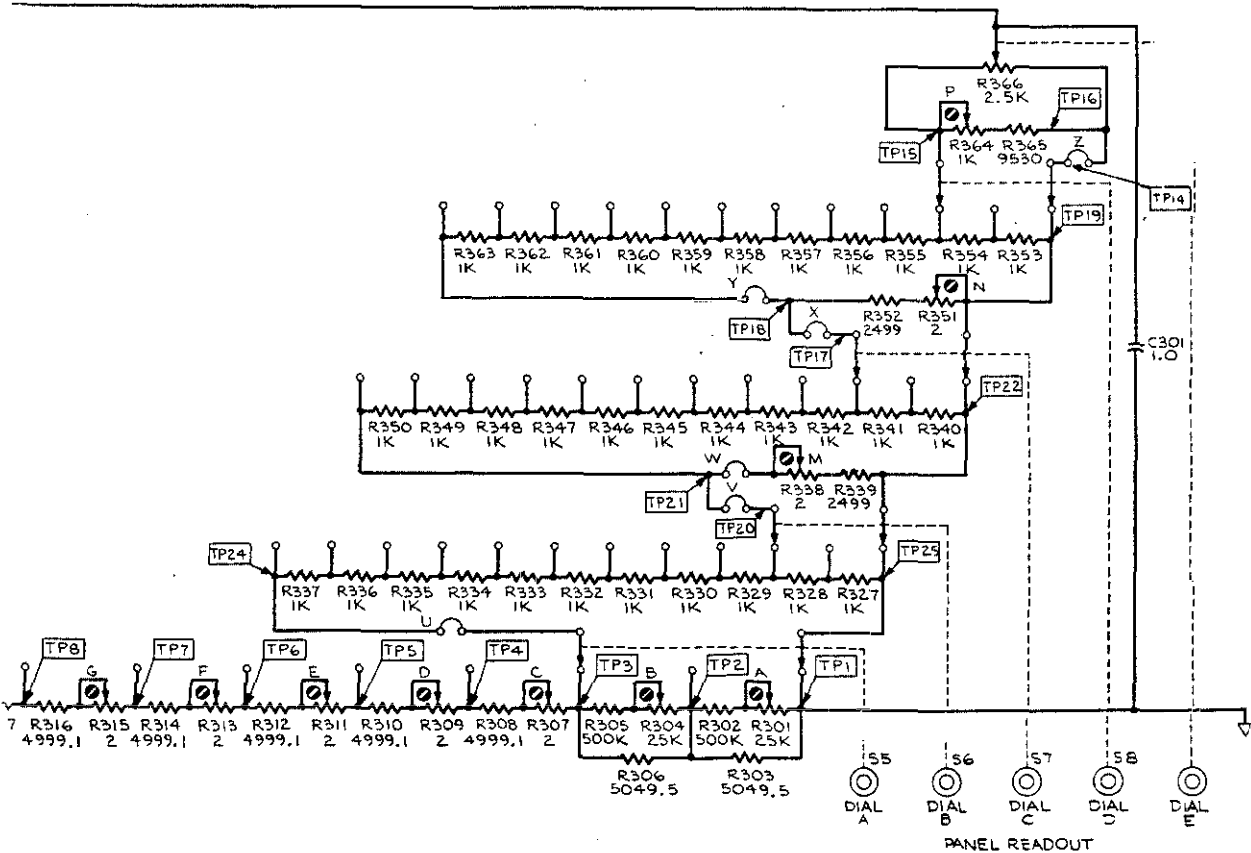
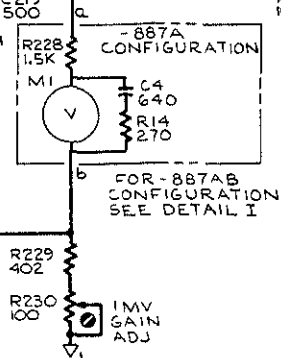
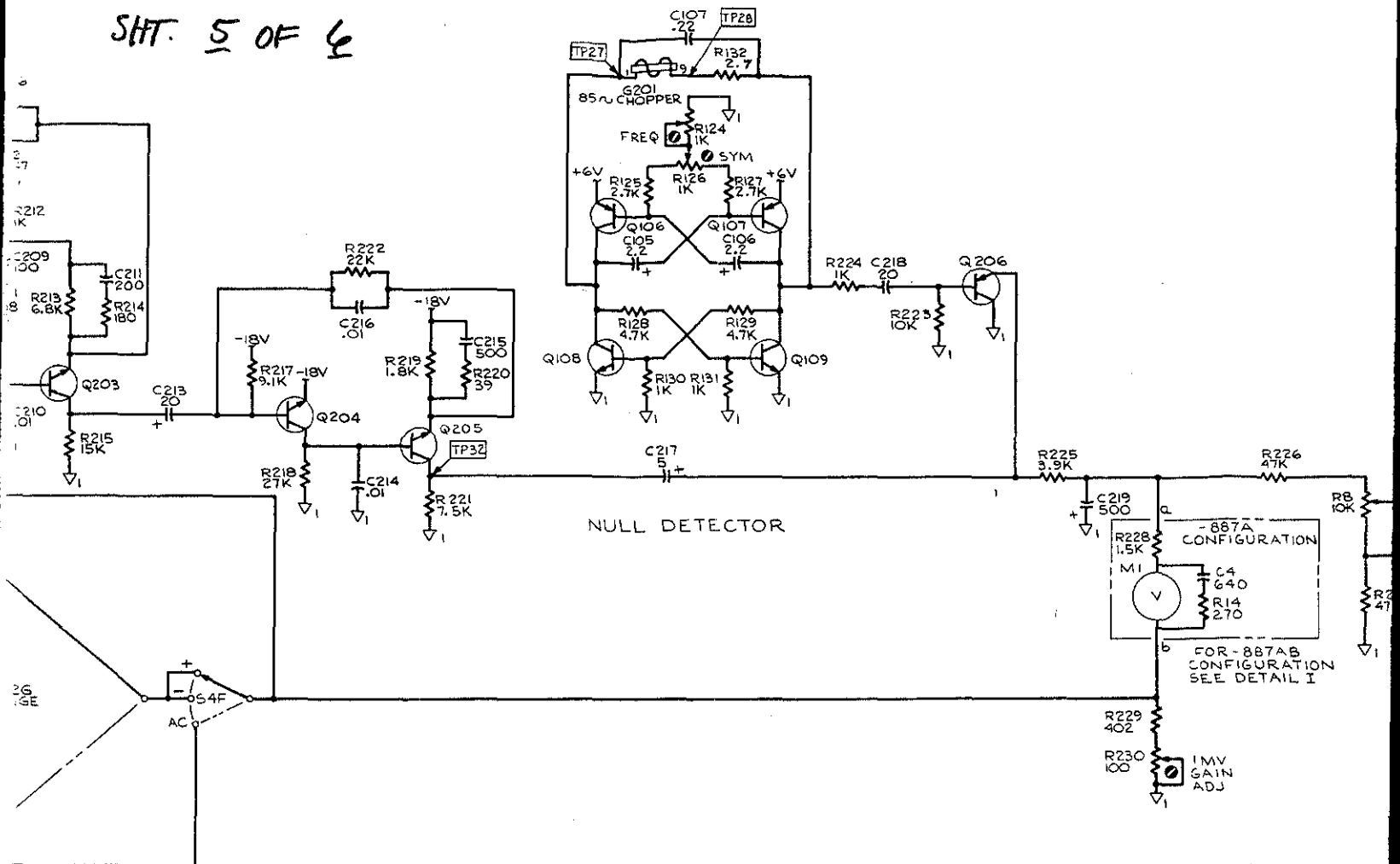

DIFFERENTIAL VOLTMETER

SHT. 6 OF 6

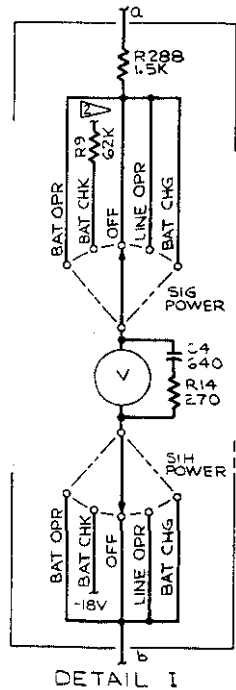
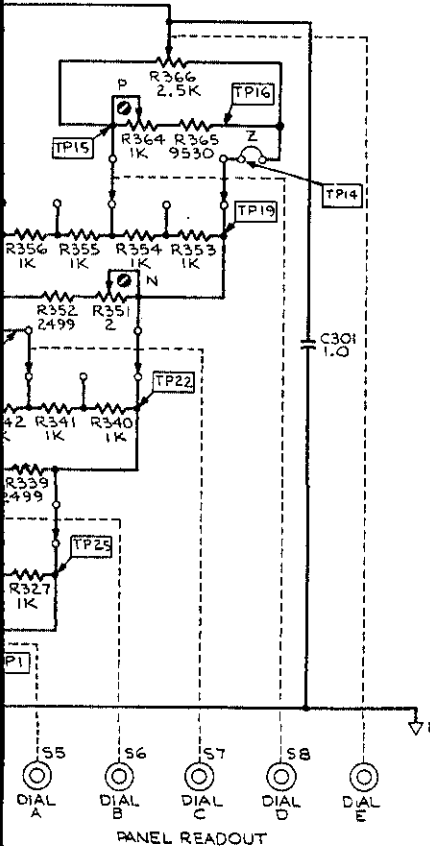
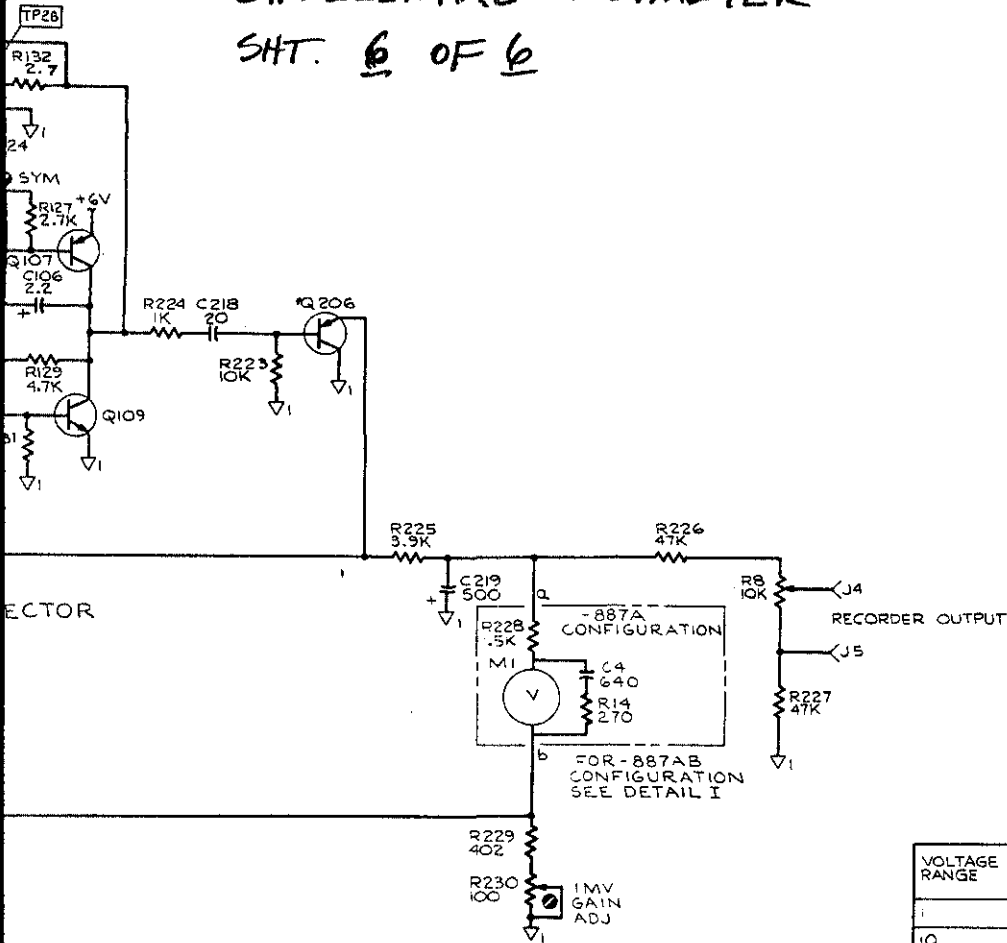

VOLTAGE RANGE	NULL RANGE			
	LO	MED LO	MED HI	HI
1	0.1	0.01	0.001	0.0001
10	1.0	0.1	0.01	0.001
100	10	1.0	0.1	0.01
1000	100	10	1.0	0.1

NOTES:

REFERENCE DESIGNATIONS

- BT-1-3
- CI-4, 101-107, 201, 301, 401-407, 501-514, 516-523
- CR-1-2, 101-104, 201-202, 501-507
- DS 201
- FI-1
- G201
- CI-6
- MI-1
- DI-2
- Q101-109, 201-206, 501-509
- R2-14, 100-107, 109-132, 201-240, 302-366
- 401-411, 501-545
- SI-8
- TI-1

▶ ALL FLAGNOTES WITH THE SAME NUMBER ARE CONNECTED.

⊕₂ INDICATES +18V RETURN.

⊖₁ INDICATES +6V AND -18V RETURN.

⊙ INDICATES INTERNAL ADJUSTMENT.

⊕ INDICATES CHASSIS GROUND.

TPXX IDENTIFIES TEST POINT.

⊗ INDICATES JUMPER.

FUNCTIONAL SCHEMATIC C

DIFFERENTIAL VOLTMETER

MODEL 887A

MODEL 887A SER. NO. 123 & ON

FLUKE JOHN FLUKE MFG. CO., INC.
P.O. Box 7428 Seattle, Washington 98133